



**Operating / Assembly Instructions  
& Installation Data**

**dw 62-1ME Steel Sliding Door**

**These assembly instructions are valid for the dw 62-1 ME steel sliding door.**

## Table of Contents

Chapter	Title	Page
<b>1.</b>	<b>General Information</b>	<b>3</b>
1.1	Types of Walls	3
<b>2.</b>	<b>Assembly</b>	<b>3</b>
2.1	Preparation	3
2.2	Maintenance/Inspections/Repairs	3
2.3	Operation/Utilisation	4
<b>3.</b>	<b>Warranty</b>	<b>4</b>
<b>4.</b>	<b>Outside Doors</b>	<b>4</b>
<b>5.</b>	<b>Arrangement of Wall Seals, Weight Boxes (optional) and Brackets</b>	<b>4</b>
<b>6.</b>	<b>Assembly Process</b>	<b>5</b>
<b>7.</b>	<b>Installation Details</b>	<b>6</b>
7.1	Fixing the Brackets	6
7.2	Fixing the Lateral Wall Seals and the Weight Box	8
7.3	Runner Rail Assembly	8
7.4	Hanging the Door Leaves and Roller Mechanism	9
7.5	Assembly of the Door Leaves	9
7.6	Fixing the Lower Guide Bracket	9
7.7	Installation of the Lower Door Track	10
7.8	Fixing the Handles to the Door Leaves	10
7.9	Wicket Door	10
7.10	End Stoppers	11
7.11	Rain Guard	11
<b>8.</b>	<b>Glazing Elements</b>	<b>12</b>
<b>9.</b>	<b>Drive</b>	<b>12</b>
<b>10.</b>	<b>Doors with Counterbalance Weight</b>	<b>14</b>
10.1	Rope Guidance and Counterweight Suspension	14
10.2	Rope Guidance and Weight Suspension	14
10.3	Assembly of the Hydraulic Brake Mechanism, Limit Stops and Magnetic Clamp	16
<b>11.</b>	<b>Special Versions</b>	<b>17</b>
11.1	Artificial Lintel	17
11.2	Advanced Limit Stop	17
<b>12.</b>	<b>General Safety Instructions for Assembly</b>	<b>18</b>
<b>13.</b>	<b>Maintenance</b>	<b>18</b>
<b>14.</b>	<b>Declaration of Conformity and CE Mark</b>	<b>18</b>
	Inspection Book for Power Operated Doors	19-24

Last Update: 15.03.05

## 1. General Information

- These installation instructions provide an overview of the current state of development.
- The utmost care has been taken to ensure that these instructions are error free. However, we shall not be liable for any possible printing errors or missing data.
- We reserve the right to make technical changes.
- In order to guarantee correct functioning and safe operation of the door only use original parts as accessories, e.g. fittings, door latches, locks, locking mechanisms. Always observe the respective assembly instructions. Spare parts and accessories can be purchased from an authorised distributor and Tekla-Technik, Tor + Tür GmbH & Co. KG.

### Important:

- In the interest of safety, only use the anchors, plugs and bolts supplied with the door for installation. The following plugs and anchors are used: For masonry Fischer FUR and for concrete Fischer FAZ or FH-S. Fixings not specified in the installation instructions require prior release by Tekla-Technik, Tor + Tür GmbH & Co. KG.
- **These instructions have been created for authorised technicians in accordance with EN 12635 requirements. Door assembly should only be carried out by technicians who fulfil these requirements.**
- Welding at the suspension should only be carried out by qualified welders (DIN EN 287-1 (Qualification test of welders - Fusion welding)).

### 1.1 Types of Wall

**The static stability of the frame and runner rail installation has to be designed for the actual weight of the door! Static inspection/documentation has to be provided by the customer!**

The sliding door can be mounted to the following walls:

- **Masonry** in accordance with DIN 1053-1, min. masonry strength class 12, min. masonry mortar group IIa, **wall thickness  $\geq 240$  mm** or
- **Concrete** in accordance with DIN 1045, min. strength class B15, **wall thickness  $\geq 140$  mm.**
- **Autoclaved aerated concrete blocks and high precision units** – in accordance with DIN 4165, min. masonry strength class 4
- **Steel constructions** with static documentation

## 2. Assembly

### 2.1 Preparation

- Ensure that the wall is plumb and level prior to assembly.
- Carry out plastering and painting work after assembling the door.
- Precisely even out any unevenness, etc. on the wall using pressure-resistant bases.
- Fix the sliding door to the adjacent constructional elements tightly enough to ensure that the static loads of the closed and open door as well as the dynamic load of the opening and closing door are permanently borne. These forces should not affect the stability of the adjacent wall.
- Ensure that the door is covered before plastering or painting work is carried out, since spots of mortar, cement, plaster or paint can damage the surface.
- Make sure that the door does not come into contact with corrosive and caustic agents such as saltpetre reactions from bricks or mortar, acids, alkalis, road salt, chlorine, corrosive paints or sealing compounds.
- Always observe and adhere to local regulations if the door is installed in explosive areas. The owner has to inform the company commissioned to install the door of these regulations.

Earthing measures should only be carried out by qualified electricians



### 2.2 Maintenance/Inspections/Repairs

The owner or a person authorised by the owner has to visually inspect the functionality of the door system regularly and to check for any external damages in accordance with chapter 1 of the maintenance information (see 1, Check List Power Operated Doors - Systems). Repair work should only be carried out by qualified technicians or Tekla-Technik, Tor + Tür GmbH & Co. KG. Immediately ensure that an unsafe door cannot be operated until it has been repaired correctly by a qualified technician or the door manufacturer. Always observe the corresponding regulations for the maintenance and inspection of power operated doors and create an inspection book. Record all carried out inspections. (see Appendix for Inspection Book)

Only replace defective parts with original ones. Please contact Tekla-Technik, Tor + Tür GmbH & Co. KG for more information.

### 2.3 Operation/Utilisation

- The ready to use door has to comply with EN 12604 and EN 12453 requirements.
- Never place objects within the movement range of the door.
- Ensure sure that nobody can be trapped or injured between objects or the wall and the opening and closing door.
- Ensure that no unauthorised people are in the opening and closing zone.

### 3. Warranty

Warranty with regard to function and safety can only be guaranteed if:

- Assembly is carried out correctly in accordance with the instructions,
- Only original parts are used,
- No additional objects are attached to the door,
- Regular maintenance of the door and its accessories is carried out,
- There is no damage caused by improper use or external influences.
- Warranty does not cover glazing elements not installed by the manufacturer. (See 12).



### 4. Outside Doors

- Check whether the intended type of mounting is correct for the planned application. For outside doors, the door should preferably be mounted on the inside and open inwards.
- Doors mounted on the outside have to be equipped with a rain guard above the roller track.
- Ensure sufficient drainage in the area in front of the door. If necessary, plan a sloping surface or a drain gutter in front of the door. Avoid a build up of water underneath the door.
- Make sure that the building is dry and sufficiently ventilated.
- It is essential to immediately paint a top coat on outside doors after assembly. The door is coated with a 2 component acrylic primer and can be painted with all standard paints.

**Caution:** The use of alkyd resin-based paints on galvanized surfaces exposed to harsh weather conditions can lead to a later loss of adhesion of the entire coating. In these cases, it is recommended to use a 2 component acrylic or a 2 component polyester primer.

**These planning, installation, maintenance and operating instructions provide an overview of the current state of development. Subject to technical changes.**

### 5. Arrangement of Wall Seals, Weight Boxes (optional) and Brackets

- Counterweight at the closing side

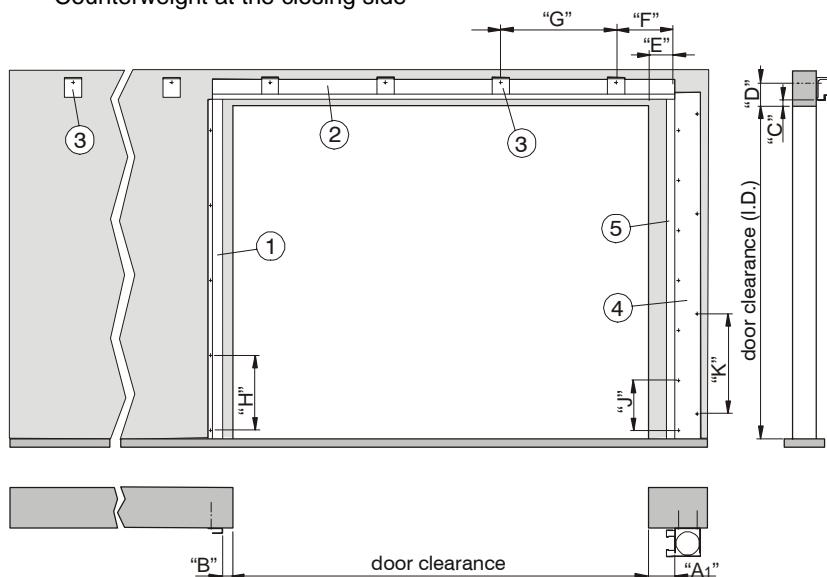

- Counterweight behind the open door

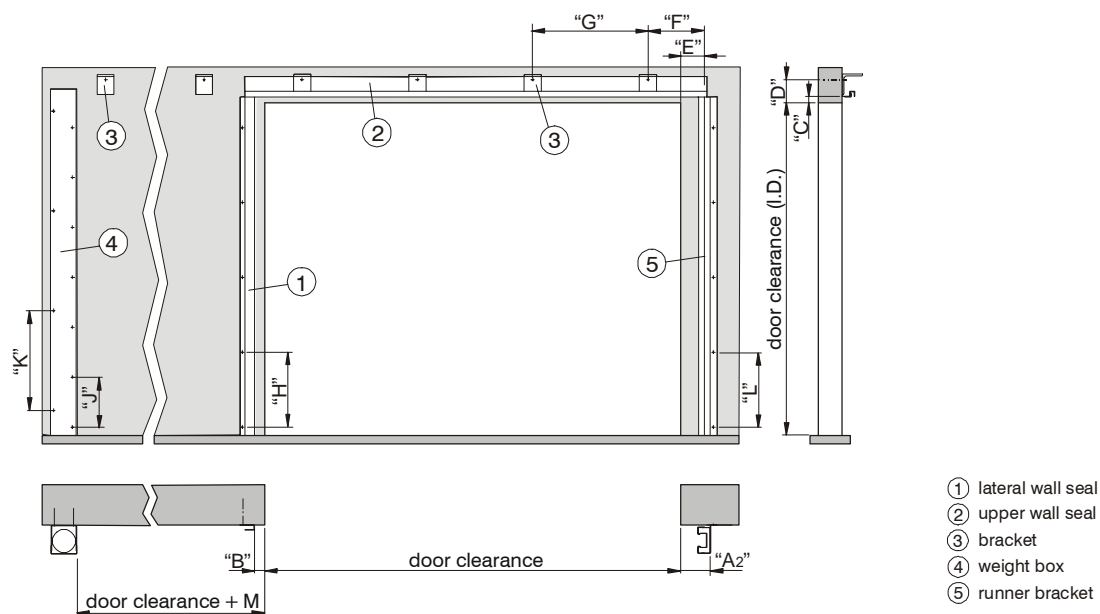

Type of Door	Door Area m <sup>2</sup>	Fixing Distances						
		"A1"	"A2"	"B"	"C"	"D"- "G"	"H"- "L"	"M"
dw 62- ME	-	-	55	5	25	Please refer to the enclosed assembly/installation instructions for dimensions	See brackets for dimensions	150

**Important:**

- Compare the door number in the assembly/installation instructions with the door number on the end panel to ensure correct assembly.

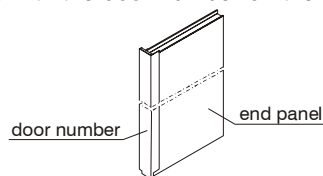

**Assembly Preparation**

Check the completeness and correctness of the delivery including the individual parts and accessories.

**6. Assembly Process**

1. Check and compare the dimensions of the wall opening with the dimensions in the assembly drawing.
2. Determine the height and lateral distances of the wall seal and brackets
3. Assemble wall seal and brackets (see 1). Assemble the run-in bracket (see 2)
4. Assemble runner rails, align, clean and coat running surfaces with a resin-free oil (see 3)
5. Hang the door leaves and roller mechanism (see 4). Start with the run-in elements.
6. Connect the door leaves at the top (see 5)
7. Connect the door leaves at the bottom (see 6)
8. Position guide shoe/roller (see 7)
9. Assemble accessories (e.g. recessed handles, wicket door, etc.) (see 8)
10. Assemble metal casing at the top (see 9)
11. Insert door

## 7. Installation Details

### 7.1 Fixing the Brackets

Prior to assembly, please refer to the assembly and installation instructions enclosed with the sliding door for all dimension and fixing information.

#### Brackets for concrete in the opening and sliding area

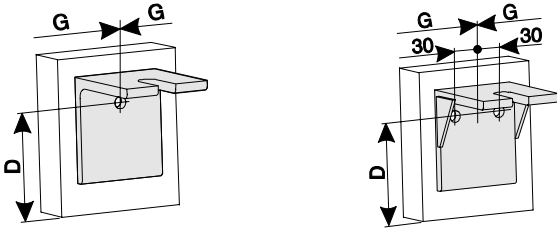
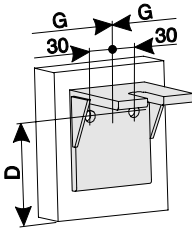
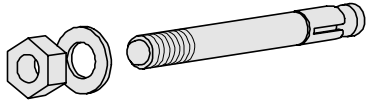
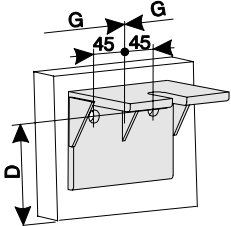
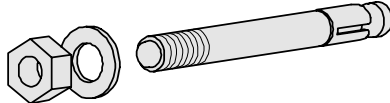
		 <p><b>Using FAZ 12/30 stay bolts</b> Drill bit: Ø12mm Drilling depth: Min. 115mm</p>
	<p>Caution: For brackets with two bore holes: Drill the first bore hole and fix and align. Subsequently drill the second bore hole</p>	 <p><b>Using FAZ 16/25 stay bolts</b> Drill bit: Ø16mm Drilling depth: Min. 130mm</p>

#### Brackets for masonry in the sliding area

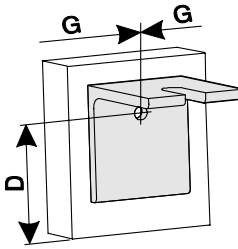
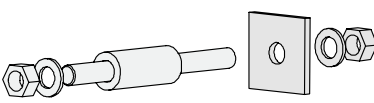
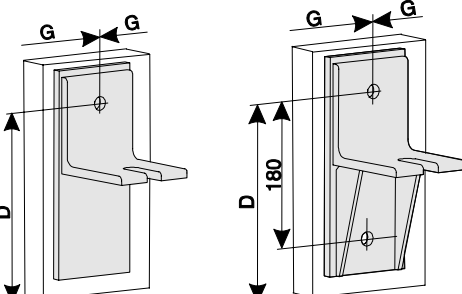
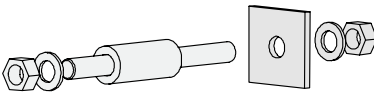
<p>Insert bolt. Fix the angle bracket using a plain washer and hexagon nut. Tighten the counter plate to the outside of the wall using a plain washer and a hexagon nut</p>		 <p>Using M12 through bolt Drilling depth: Through bore Drill bit: Ø12mm Drill bit for sleeve: Ø30mm Drilling depth for sleeve: Min. Ø80mm</p>
	<p>Caution: For brackets with two bore holes: Drill the first bore hole and fix and align. Subsequently drill the second bore hole.</p>	 <p>Using M16 through bolt Drill bit: Ø16mm Drilling depth: Through bore Drill bit for sleeve: Ø30mm Drilling depth for sleeve: Min. Ø80mm</p>

#### Brackets for ceiling mounting

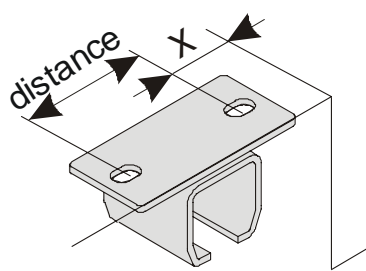
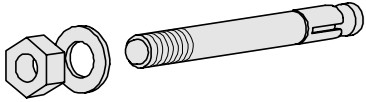
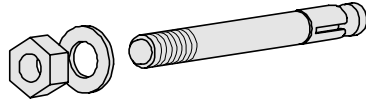
	 <p><b>Using FAZ 12/10 stay bolts</b> Drill bit: Ø12mm Drilling depth: Min. 95mm Distance: 94mm Dimension "X": 51mm</p>	 <p><b>Using FAZ 16/25 stay bolts</b> Drill bit: Ø16mm Drilling depth: Min. 130mm Distance: 124mm Dimension "X": 36mm</p>
---	--	--

**Alternative bracket fixing by welding onto a bracket preset in concrete**

<p><b>Lintel mounting</b></p>	<p><b>Ceiling mounting</b></p>	<p>Set the bracket plate in concrete while constructing the lintel or ceiling. Weld the angle brackets or ceiling brackets to the bracket plates. (See 1 "General Instructions – bullet 7!")</p>
-------------------------------	--------------------------------	--

**Assembly of the angle and ceiling brackets**

- Check height over the entire width (observe unevenness of the floor!)
- For wall mounting  
Measure the height for the angle brackets from the highest point of the floor (for rough concrete from the metre level). It is essential to observe the minimum dimension "D" (see table above) from the lower edge of the lintel to the bracket bore holes. Mark further divisions using a tube level or surveyor's level.
- **For ceiling mounting**  
Measure the distance from the lower edge of the ceiling to the highest point of the floor. Subsequently fix the ceiling mounting bracket to the lowest point. Mark further divisions using a tube level or surveyor's level. Position the ceiling mounting brackets with flat steel for metal casing attachment (see 9) at equal distances.

**Fixing the upper wall seals**

**For wall mounting**

<p>Fix all the wall brackets together with the upper wall seal, since one side of this wall seal is jammed between the lintel and the angle bracket</p>	
---	--

**For ceiling mounting**

	<p><b>Using FAZ 12/10 stay bolts</b> Drill bit: Ø12mm Drilling depth: Min. 95mm</p>
--	---

**For brackets set in concrete**

<p>Weld the wall seal to the bracket plates.</p> <p>Welding (s): <math>a \geq 4</math>, <math>l \geq 30</math>mm</p>	
--	--

## 7.2 Fixing the Lateral Wall Seals and the Weight Box:

### For weights at the closing side (weight box optional)

- Bolt on the weight box (1)
- Fix the run-in bracket (2) to the weight box using steel blind rivets  $\varnothing$  4x8mm or plug welding.
- Bolt on the lateral wall seal (3)
- Fix the upper wall seal (4) (see above)

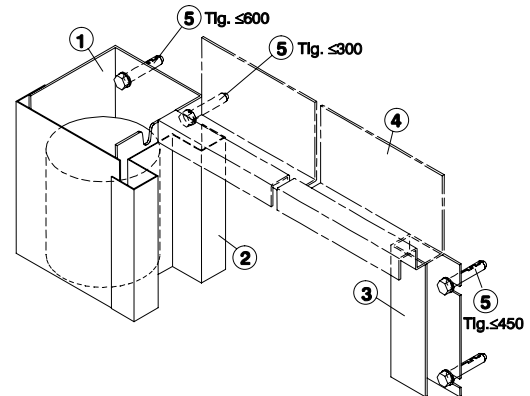

Tlg. = division

See tables for fixing equipment (5)

Push the lateral wall seal up underneath the upper wall seal. The lateral wall seal (3) has to be fixed in place before hanging the last door leaf otherwise it is covered and no longer accessible.

### For weight box behind the open door (weight box optional)

- Attach the weight box (1)
- Bolt on the wall seal (3)
- Fix the run-in (2) (see below).

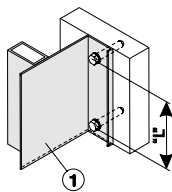

Run-in bracket for dw 62 multi-purpose sliding doors. Attach run-in bracket. Fix upper and lateral wall seal.

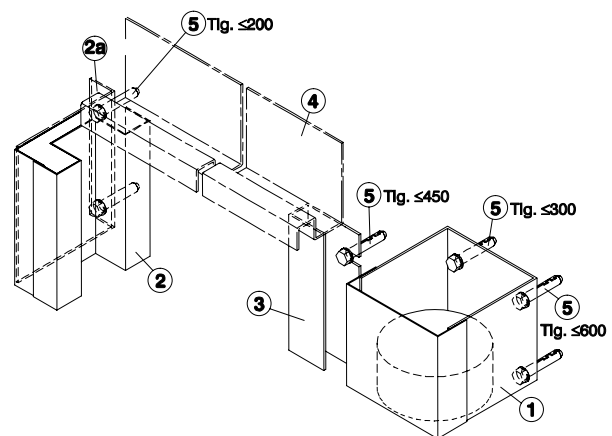

### Fixing equipment for wall seals and counterweight

- For concrete:                   - Use  $\varnothing$ 12mm expansion anchor; ( $\varnothing$ 12mm drill bit, min. drilling depth 50mm)  
    - Use M10 heavy duty anchor; ( $\varnothing$ 10mm drill bit, min. drilling depth 80mm)
- For masonry:                   - Use  $\varnothing$ 12mm synthetic plug; 135mm long; ( $\varnothing$ 12mm drill bit, min. drilling depth 150mm)
- For autoclaved aerated concrete: - Use M12 through bolts

## 7.3 Runner Rail Assembly

- Use a cloth soaked in resin-free oil to clean the inside of the runner rail
- For wall mounting:
  - Fix the sleeves to the brackets and align.
  - Insert the runner rail into the sleeves.
  - Attach the runner rail and the sleeves at the same time if there is a shortage of space.
- For ceiling mounting
  - Insert the runner rail into the ceiling mounting sleeves.
  - Attach the runner rail and the sleeves at the same time if there is a shortage of space.

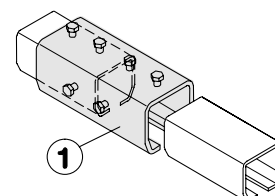
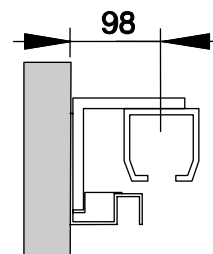

Use a connection sleeve (1) to interconnect several runner rails.



#### 7.4 Hanging the Door Leaves and Roller Mechanism

- Screw the carrier bar into the bore hole in the door leaf
  - Insert the roller mechanism into the runner rail
  - Place the door leaf underneath the roller mechanism
  - Screw together the roller mechanism and the carrier bar.
- Adjust to the correct height to ensure precise running of the roller mechanism by screwing the carrier bar in the door leaf clockwise or anti-clockwise (minimum screw-in depth of the carrier bar = 25mm)
- The roller mechanism can be completely screwed into the door leaf for larger spaces. Subsequently insert the door leaf together with the roller mechanism into the runner rail from the rear. For doors with counterweight balance at the first roller mechanism, as viewed from the closing side, attach the metal clip for the traction rope complete with rope when screwing in the carrier bar.

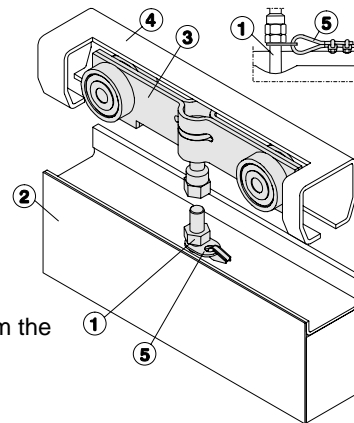

#### 7.5 Assembly of the Door Leaves

- Using leaf connector  
After pushing together the single leaves (1 + 2) (tongue and groove system) in package order, use the leaf connector (flat steel) to connect them, screw it tight using hexagon nuts (M 8) and plain washers (for elongated holes) or without washers (for bore holes).
- A tensioning strap can be used to hold the the door leaves in place in order to screw the door together at the nominal width.

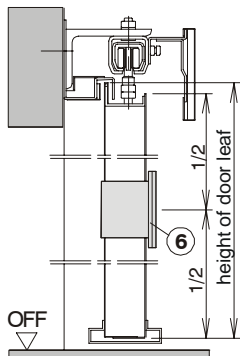
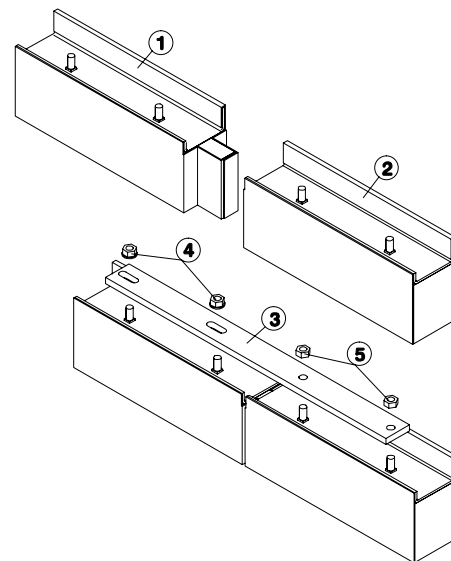

OFF (upper edge finished floor)

- Tilting lock for clear opening width of >5,000mm or height of >4,000mm and for wicket door with a sill. Use the tilting lock to interconnect the leaves. Subsequently align and connect using the leaf connector (see above). **CAUTION!** Leaves connected with a tilting lock cannot be disassembled – observe the correct leaf order!

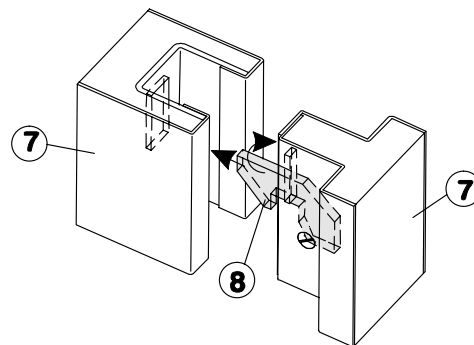

#### 7.6 Fixing the Lower Guide Bracket

Push the lower guide bracket (9) over the leaves (10). Align it to the floor (see diagram 6.1) and fix it to the leaves using 4.8x16mm self drilling screws (11) in the pre-drilled holes. At the run-in side (12), the guide bracket has to be 50mm from the edge.

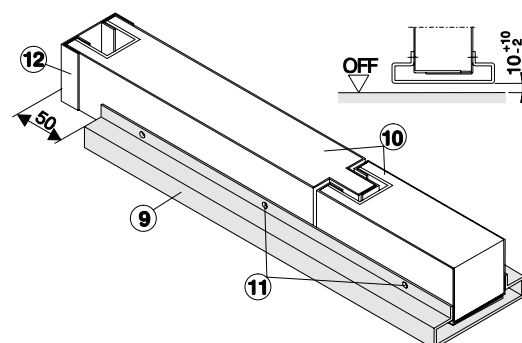

### 7.7 Installation of the Lower Door Track

#### For sliding doors without wicket door and for wicket door with sill

Fix the guide shoe (1) in front of the run-in bracket (2) and the guide roller (3) in front of and behind the lateral wall seal.

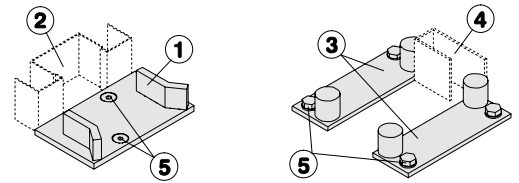

#### For sliding doors with wicket door without sill

Fix the guide shoe (1) in front of the run-in bracket (2), see above, and the guide shoe (6) behind the lateral wall seal (4). Two guide shoes (6 & 1) are additionally positioned in the sliding area in accordance with the dimensioned diagram.

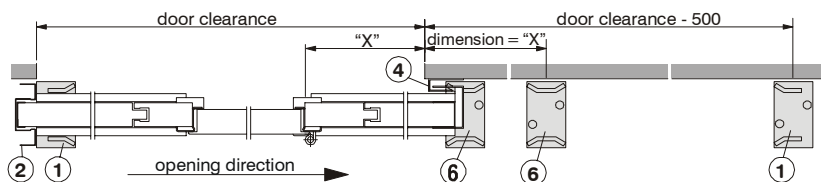
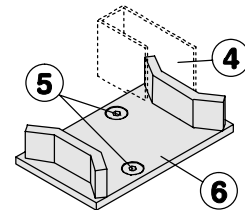

#### Fixing the Door Track

For finished floor – using expansion anchor  $\varnothing 10\text{mm}$ . All the necessary plugs and anchors are included in the accessory pack. For rough concrete, use an appropriate underfill material to which the tracks can be welded.

### 7.8 Fixing the Handles to the Door Leaves

#### - Recessed Handles

##### Both sides

Fix the recessed handles (10) using the sleeve screws (11) and M5x50mm countersunk screws (12)

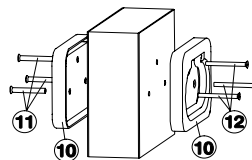

##### One side

Fix the recessed handle (13) using ST4.8x13mm sheet metal screws (14)

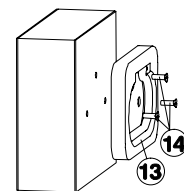

#### Handle bars

##### Type 1

Use M6x16mm counter sunk bolts (16) and the blind rivet nuts (17) in the door leaf to fix the handle bar (15) into position.

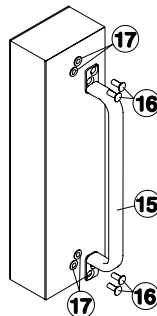

##### Type 2

Use M8x25mm counter sunk bolts (19), washers and the blind rivet nuts (20) in the door leaf to fix the handle bar (18) into position.

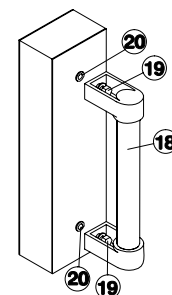

### 7.9 Wicket Door

#### - Wicket Door with Sill:

Hang the leaves (1; 2 and 3) and interlock them using the tilting lock (4). Align and connect the leaves at the top using the leaf connectors (5) (see 5).

Insert the bottom sill (6) between the leaves (1 and 3) and clamp tight.

Hang the wicket door, insert the ball bearings (7) and knock in the hinge bolts (8) (see diagram right and general hinge information).

Use a set screw (9) to fasten the hinge.

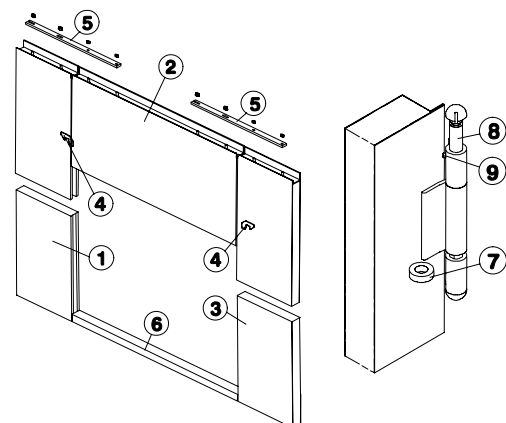

*Caution: It is strictly forbidden to use wicket doors with sills for escape routes and emergency exits!*

**Wicket door without sill:**

Install and align the leaf together with the wicket door.  
Use the leaf connector to connect the upper leaves (see 5).  
Additionally screw the 3 M10x210mm countersunk screws (10) through the door frame into the adjacent leaf on the hinge side.

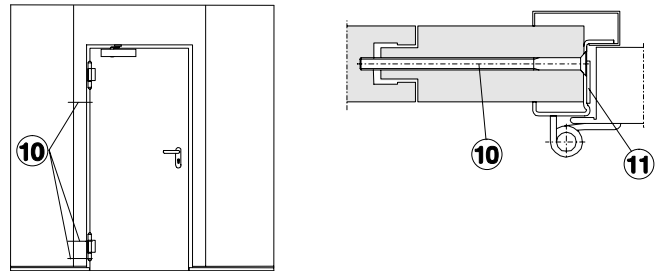

Use 2 M5x50mm countersunk screws (13) with sleeve screws to fix the guide bracket (see 6) in the wicket door area on the hinge sides.

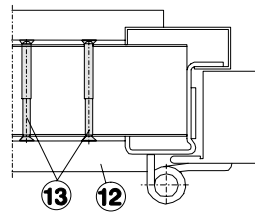

**Sliding door track:**

Additionally fix two guide shoes in the sliding area (see 7 with the respective diagram)

**General hinge information:**

- Lubricate hinge bolts
- When knocking in the hinge bolts, ensure that the notch (14) is positioned in the hinge bracket gap.



**Installation of the door latches and door closer**

- Assemble the door latches. Install the flat latch facing the wall
- Assemble and adjust the door closer. The setting has to ensure that the door closes automatically from any opening angle. (Please refer to the instructions of the respective upper door closer for assembly and adjustment instructions)
- Check closing function (the wicket door has to close from every possible position)
- Check latch bolt contact (min. 6mm)

*Note: The wicket door position of sliding doors with an automatic electric drive has to be checked via magnetic contacts (2 contacts integrated into the frame and door leaf). The door should only move if the wicket door is completely closed. Refer to the enclosed wiring diagram for the connection diagram.*

**7.10 End Stoppers**

Use hexagon bolts (3) and clamp (4) to fix the end stoppers (2). Attach the end stoppers when the door is either open or closed so that they come up against the roller mechanism.

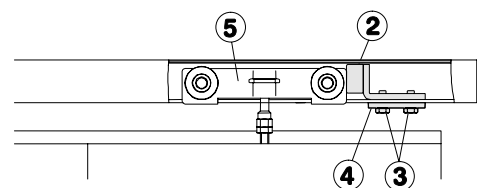

**7.11 Rain Guard**

(Optional extra, e.g. for outside doors)  
Position the rain guard (6) and fix it to the mounting brackets (8 and 9) using 4.8x16mm self drilling screws (7).

Outside doors: The customer should seal the upper gap between the rain guard and the lintel/wall.

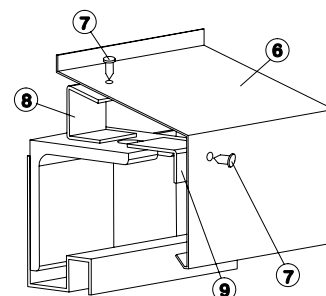

## 8. Glazing Elements

Various glass and glazing elements can be supplied.

Glazing elements are fixed in rubber frames by the manufacturer. However, glazing elements can also be fixed in aluminium profiles by the customer.

- The manufacturer shall assume no liability for injuries or damage to persons or property caused by non shatter-proof glass or incorrect installation by third parties.
- The manufacturer only installs shatter-proof glass which complies with the requirements of DIN EN 12600.
- Please note that any replacement glass has to have the same performance properties in accordance with DIN EN 12600 as regards impact resistance, etc. as the glazing elements installed by the manufacturer.
- Please contact *Tekla-Technik, Tor + Tür GmbH & Co. KG* for more information about permissible and manufacturer installed glazing elements.
- Glazing work should only be carried out by qualified personnel. The retrofitting of door leaves with transparent panels (glass) is strictly forbidden.

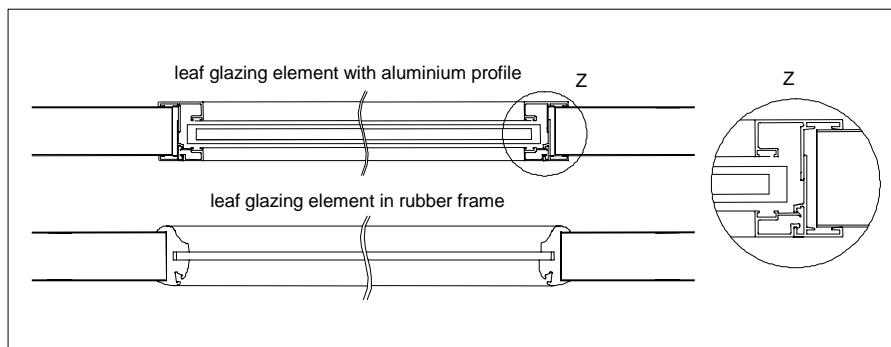

## 9. Drive (special version)

dw 62 ME sliding doors can optionally be equipped with an electric drive with either “deadman” or “pulse function”. The control button OPEN or CLOSED has to be pressed continuously for door movement with an electric drive with “deadman operation”.

For automatic or pulse function, door movement OPEN, CLOSED or STOP is triggered via a pulse at the button. The buttons only have to be pressed briefly during pulse operation. A remote control or similar device can be optionally integrated.

### Right-hand version: “drive - lintel assembly”

Electric drive with the drive rail attached to the runner rail.

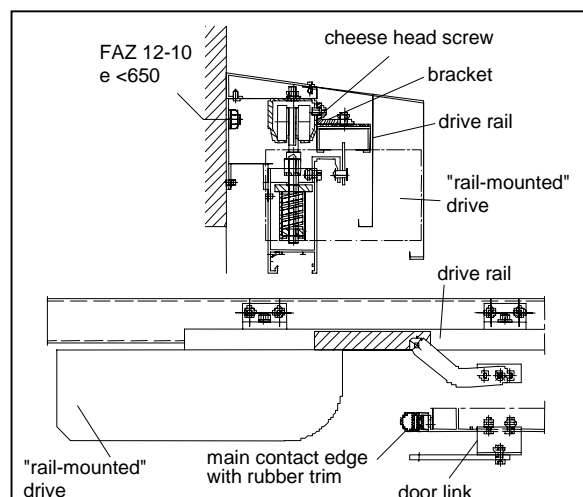
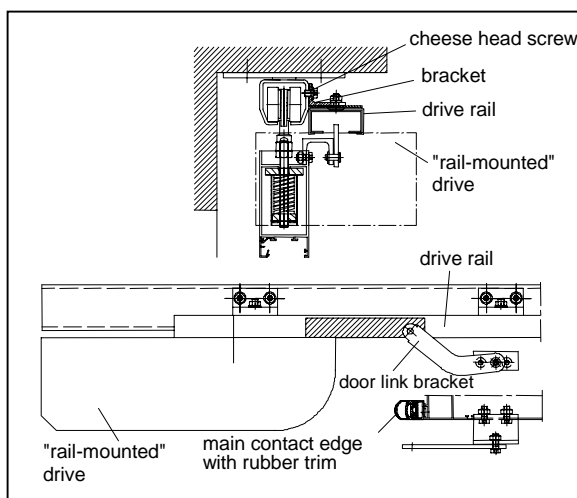

### Left-hand version: “drive - ceiling mounting”

Electric drive with the drive rail attached to the runner rail.

### **Assembly instructions for sliding doors with CarTeck 252 electric drive**

**Important:** The electric drive stated below (Marantec, type 252) should only be used for doors with a leaf area of  $\leq 25\text{m}^2$ . This drive is not permitted for larger leaf areas.

- Open the door in order to install the guide rail.
- Use the fixing brackets to install the guide rail in front of the runner rail (see diagram)
- Lengthwise, the guide rail should be set so that the end position of the door link bracket in the guide rail is at least 100mm behind the fully open door, i.e. that the door link bracket can never move to the end of the rail. The same applies for the closed position.

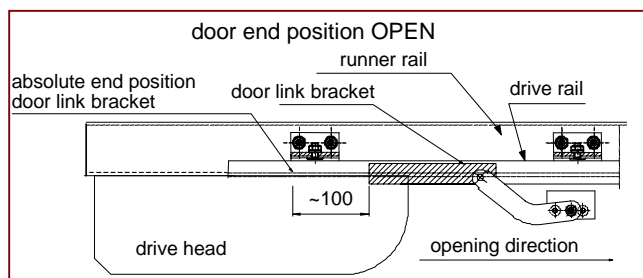

Programming the electric drive in accordance with the CarTeck Installation and Operating Instructions Parts 1+ 2

Before programming the electric drive it is important to check whether the door runs freely in the parallel running guide rail. The door link bracket of the guide rail has to be unlocked for this task (see Fig. D10 - D12, Installation Instructions Part 2). Subsequently check whether the door and guide rail run smoothly without jamming along the entire travel of the door (end position open and closed).

Ensure that the door link bracket has locked into place in the guide rail prior to programming! (see D23, Installation Instructions Part 2)

- Programming procedure for basic drive functions page 26 of the Installation and Operating Instructions Part 1
- Programming end position OPEN and CLOSED page 28 – 29. Caution: When programming the end position CLOSED, ensure that the rubber trim of the main contact leaf edge is not resting on the run-in bracket! The distance between the rubber trim and the run-in bracket has to be approx. 2 – 5mm (see diagram)

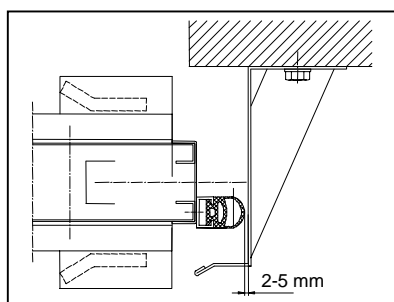

A warning sign should be placed in the area of the wall soffit for doors with Marantec automatic operation. This sign has to warn of the potential dangers resulting from automatic door closing.



- Programming radio control page 30
- Programming automatic switch-off OPEN and CLOSED. With this function, the upper power limit of the drive for OPEN and CLOSED movement has to be set to the smallest value sufficient enough to move the door (pages 36 – 39)
- Programming SOFT STOP CLOSED (page 54). *The factory setting for the Soft Stop Closed is 200 mm. Select the fourth programming level. Change the Soft Stop Closed from 200 to 500mm, subsequently exit the programming level.*
- Any other program level and steps should only be selected and changed in special cases.

**Note:** Only use electric drives tested and released by the door manufacturer. Contact Tekla-Technik, Tor + Tür GmbH & Co. KG for information about which drives have been tested and released for your requirements when retrofitting a drive to a manually operated door. (Also see 14. Declaration of Conformity)

Always observe the respective Schnetz installation instructions for doors with deadman drive type. ATS...WST from Schnetz

**Note: BMH hook bolt lock**

The door can be equipped with a hook bolt lock by the manufacturer. An information sticker should be affixed to both sides of the door leaf in the lock area to explain lock functioning and prevent damages. The information stickers are included in the accessories if the door has been equipped with this type of lock by the manufacturer.

Information for sliding doors fitted with a triple action BMH hook bolt lock: This information sticker should be affixed to both sides of the door leaf directly next to the profile lock. Also refer to the Planning, Installation and Maintenance Instructions for 1 & 2 leaf sliding doors and elements.

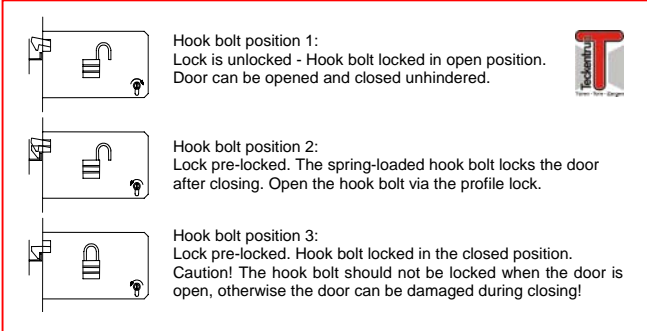

**Hook bolt position 1:**  
Lock is unlocked - Hook bolt locked in open position.  
Door can be opened and closed unhindered.

**Hook bolt position 2:**  
Lock pre-locked. The spring-loaded hook bolt locks the door after closing. Open the hook bolt via the profile lock.

**Hook bolt position 3:**  
Lock pre-locked. Hook bolt locked in the closed position.  
Caution! The hook bolt should not be locked when the door is open, otherwise the door can be damaged during closing!

**10. Doors with Counterbalance Weight (special version)**

**10.1 Rope Guidance and Counterweight Suspension**

- Rope fixing

Assemble the weight box according to 1.5. Fix the rope to the roller mechanism and the weight suspension; use 3 rope clamps (7). Hang and counterbalance the weights (see 2.6). Hang and counterbalance the weights (see 2.6). Fix the weight box cover according to 2.6.

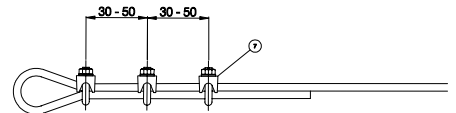

Ensure that the rope and the weights do not catch on protruding rivets, screws or bolts.

*Rope guidance in the weight boxes*

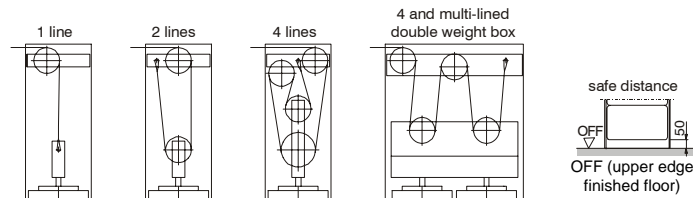

Caution: Ensure that the weights are 50mm (safe distance) above the finished floor.

**10.2 Rope Guidance and Weight Suspension:**

- For counterweight at the closing side (Wall and ceiling mounting)

**Rope guidance:**

**Caution:** In order to attach the rope, fix the clip with the rope (1) to the first roller at the closing side (see 2.1). Feed the other end of the rope (2) downwards over the weight box roller and fix it to the rope eye of the weight suspension with 2 rope clamps [see 2.5].

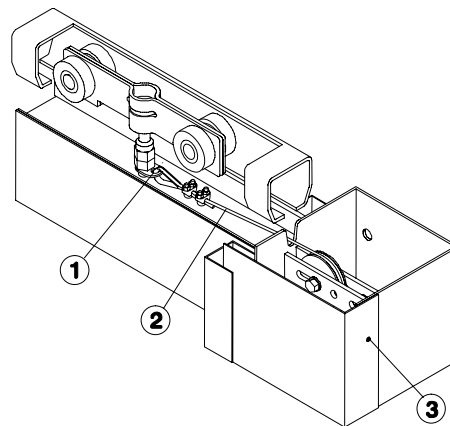

**Weight suspension:**

Hang and counterbalance the weight (see below). The L-shaped weight box cover is placed in the insulating seat of the run-in bracket and laterally fixed using M6x8mm cheese head screws (3) (3x at the same height).

- For counterweight behind the open door

Wall mounting

**Rope guidance:**

*Caution:* In order to attach the rope, fix the clip with the rope (4) to the first roller at the closing side (see 2.1)).

- Screw or weld a double rope deflection pulley (7) to the runner rail (6)
- Feed the other end of the rope (5) above or in front of the runner rails/brackets downwards over the weight box roller and fix it to the rope eye of the weight suspension with 2 rope clamps [see 2.5].

**Weight suspension:**

Hang and counterbalance the weight.

Fix the weight box cover to the weight box bracket on both sides using M6x8mm cheese head screws (5) (3x at the same height).

**Weight counterbalance:**

Only use the amount of weight required for safe closing of the door.

The door has to open with a max. force of 200 N.

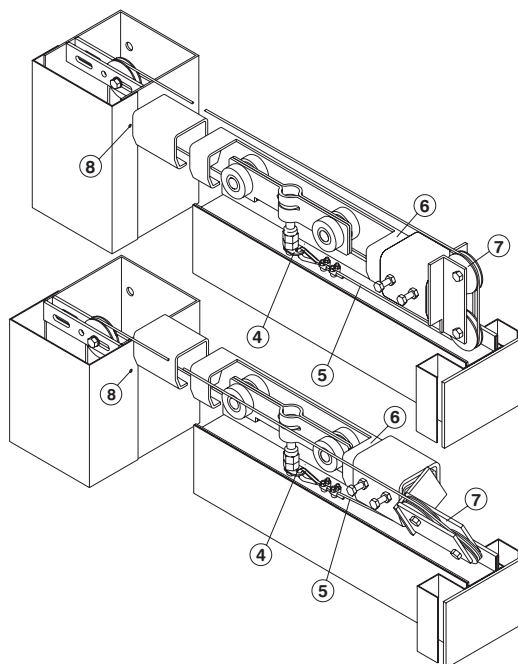

• **Standard Version**

Fix the rope anchorage (1) to the last panel - viewed from the closing side - using 2 M6x20mm bolts. The rope tension pulley (2) is fixed to the last runner rail sleeve using its hexagon bolts (sleeve distance from edge of door is min. 400mm). The rope tension pulley (2) is located in front of the rope anchorage (1). The bracket (A) with the hydraulic brake mechanism (3) is bolted tightly to the end of the runner rail using the M10x40mm hexagon bolts and the clamp (C). Adjust the hydraulic brake mechanism so that the closing velocity does not exceed 0.2m/s or fall below 0.08m/s. Tension the wire rope (4) via the spring-suspended tension pulley (2) until it can no longer slip. The limit stops are

adjustable hydraulic brake cylinders (end brakes (5+5a). For the position "door CLOSED", screw an end brake (5) into the bracket (B) 100/50/5, which has been previously fixed to the door leaf, using 4 M5x20mm bolts. The end brake comes up against the brackets (6) to be fixed to the runner rails – the brackets are attached with clamps just like bracket (A). In the opening direction, the door comes up against the end brake (5a) located in bracket (A). For larger doors, bolt a magnetic clamp (6) to bracket (A) using M4x10mm bolts. Fix the magnetic clamp counterplate (6a) to the base plate on the rear door leaf using M4x8mm bolts. Weld or bolt the base plate to the door leaf seal in advance. Use M8x30mm bolts for the latter option.

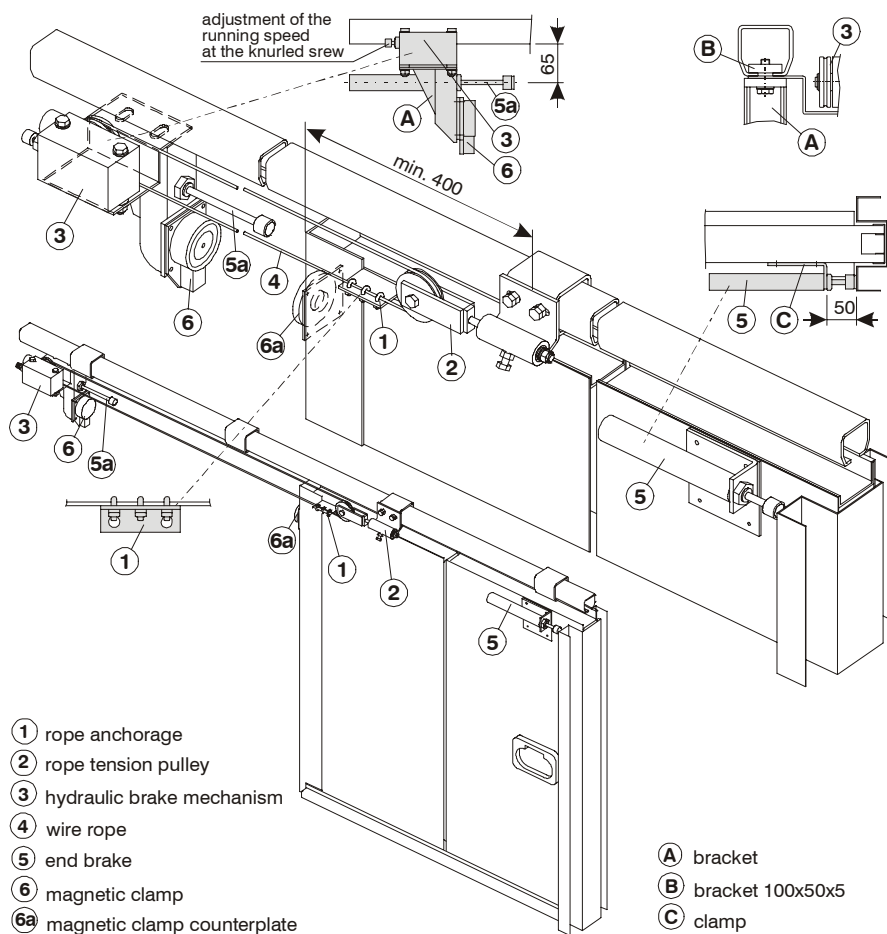

- ① rope anchorage
- ② rope tension pulley
- ③ hydraulic brake mechanism
- ④ wire rope
- ⑤ end brake
- ⑥ magnetic clamp
- ⑥a magnetic clamp counterplate

- Ⓐ bracket
- Ⓑ bracket 100x50x5
- Ⓒ clamp

• **Shortened Stop**

Fix the rope anchorage (1) to the last panel - viewed from the closing side - using 2 M6x20mm bolts. The rope tension pulley (2) is fixed to the last runner rail sleeve using its hexagon bolts (sleeve distance from edge of door is min. 400mm). The rope tension pulley (2) is located in front of the rope anchorage (1). The bracket (A) with the hydraulic brake mechanism (3) is bolted tightly to the end of the runner rail using the M10x40mm hexagon bolts and the clamp (C). Adjust the hydraulic brake mechanism so that the closing velocity does not exceed 0.2m/s or fall below 0.08m/s. Tension the wire rope (4) via the spring-suspended tension pulley (2) until it can no longer slip. The limit stops are adjustable hydraulic brake cylinders (end brakes (5+5a). For the position "door OPEN", "door CLOSED", screw the end brakes (5+5a) into the bracket (B) 100/50/5 which has been previously fixed to the door leaf using 4 M5x20mm bolts. The end brake comes up against the brackets (6) to be fixed to the runner rails – the brackets are attached with clamps just like bracket (A). In the opening direction the end brake (5a) comes up against the bracket (A).

For larger doors, bolt a magnetic clamp (7) to bracket (A) using M4x10mm bolts. Fix the magnetic clamp counterplate (7a) to the base plate on the rear door leaf using M4x8mm bolts. Weld or bolt the base plate to the door leaf seal in advance. Use M8x30mm bolts for the latter option.

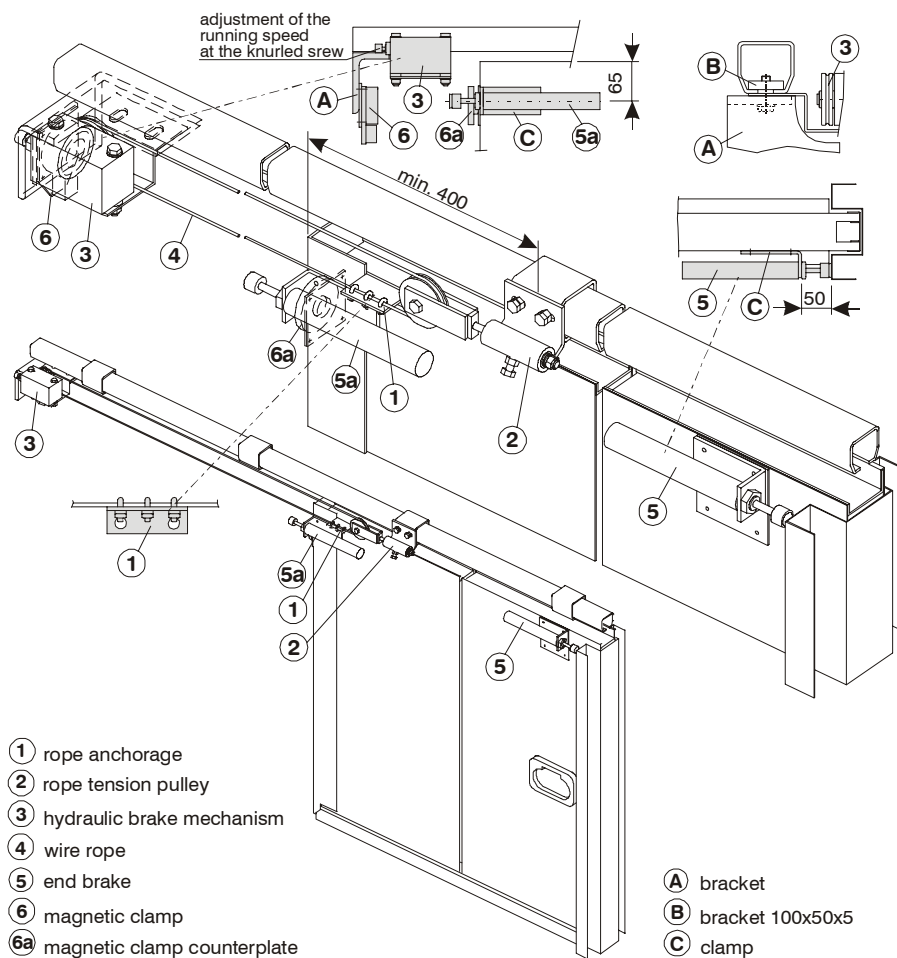

**10.3 Assembly of the Hydraulic Brake Mechanism, Limit Stops and Magnetic Clamp**

In the opening direction, the end brake (5a) comes up against the bracket (A). For larger doors, bolt a magnetic clamp (6) to bracket (A) using M4x10mm bolts. Fix the magnetic clamp counterplate (6a) to the base plate on the rear door leaf using M4x8mm bolts. Weld or bolt the base plate to the door leaf seal in advance. Use M8x30mm bolts for the latter option.



## 11. Special Versions

### 11.1 Artificial Lintel

- Screw the box section (1) with the 50mm wide insulating strip (2) to the ceiling [Ø7mm countersunk screws (3) with 10/200 plug (4) – Ø 10 drill bit, drilling depth min. 100mm].
- Fix the housing (5) with the insulating strip to the ceiling [FAZ 12/10 plug (6); e≤500, Ø12mm drill bit, drilling depth min. 95mm]
- Laterally screw the insulating strips (7) with the upper wall seal (8) to the box section (1) [M8x45mm hexagon bolt (9) with washer].
- Subsequently connect the housing (5) to the wall seal (8) [M5x40mm cheese head screw (10) ; e≤500].

Fix the ceiling sleeve (11) as described in 1.4.

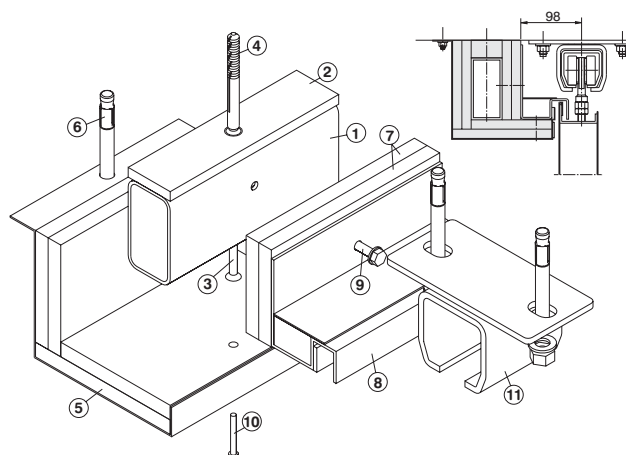

### Runner rail casing (optional)

#### Type "A"

- Fix the runner rail casing to the rail sleeve according to 2.8 (runner rail casing-ceiling mounting).

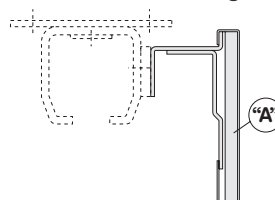

#### Type "B"

- Fix the runner rail casing to the ceiling [FAZ 12/10 plug (12); e≤500, Ø 12mm drill bit, drilling depth min. 95mm]

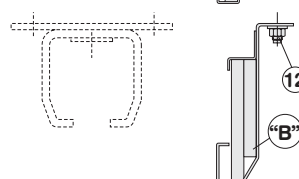

### 11.2 Advanced Limit Stop

Assembly and commissioning of the hydraulic brake mechanism, limit stops and magnetic clamp occur as described in 2.7. (The sleeve distance for fixing the tension pulley has to be at least 600mm from the edge of the door)  
The limit stop (7) is fixed (as displayed) to the door by the customer at the last panel – as viewed from the closing side - (4.8x16mm bolts or welded).

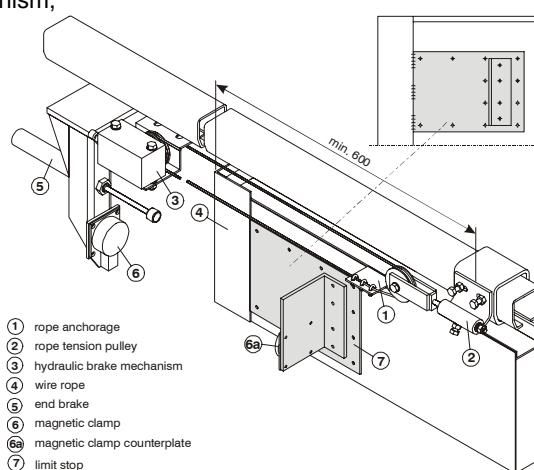

- ① rope anchorage
- ② rope tension pulley
- ③ hydraulic brake mechanism
- ④ wire rope
- ⑤ end brake
- ⑥ magnetic clamp
- ⑥a magnetic clamp counterplate
- ⑦ limit stop

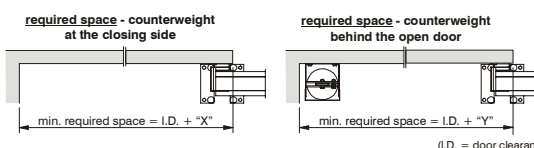

	Dimension "X"
≤34m <sup>2</sup>	150
>34m <sup>2</sup>	350
	Dimension "Y"
≤34m <sup>2</sup>	300
>34m <sup>2</sup>	500

**Caution!** Correct functioning and installation according to the instructions has to be determined by an acceptance test and documented in an "Inspection Book for Hold Open Devices" after the installation of sliding doors with hold open devices. The manufacturers of release devices and hold open devices should draw attention to this test. The operator has to make sure that the necessary steps are taken.

**The acceptance test should only be carried out by specialists of or authorised by the release or hold open device manufacturer or specialists of a specified inspection authority.**



## 12. General Safety Instructions for Assembly

- Always observe the maximum permissible loads when using lifting gear and devices. The weight of the door is approx. 28kg/m<sup>2</sup>.
- Only use intact and certified lifting devices (assembly cranes, fork lifts) and lifting gear (cables, chains, belts).
- Before lifting the elements ensure that the load is secured correctly and that it can neither become loose nor slip. The elements can suddenly jerk and swing – beware risk of injuries!
- During assembly avoid wind loads on the not fully assembled door, e.g. in thoroughfares or subways. Close or secure all openings in advance.
- During the entire assembly period ensure that individual door elements and components cannot fall down or be knocked down.
- Always wear suitable protective clothing (protective gloves, hats, boots, etc.) during assembly.



- Always use scaffolding or lifting platforms to carry out assembly work at >2 m.
- Ensure that unauthorised persons cannot enter the installation area during assembly.
- Plan disassembly in accordance with local conditions.
- Disassembly is carried out in reverse order to assembly. Observe the specified assembly safety instructions.



*Caution: The disassembly steps have been designed for undamaged, fully functional doors. However, if a door has to be disassembled due to damage, the type of damage is decisive for the disassembly procedures. The steps listed below are, therefore, only intended as a rough guide in such cases. The sequence of actions may change or not be necessary depending on the situation and damage. Disassembly should always be carried out with the utmost care and attention and under the supervision of a specialist.*

## 13. Maintenance

Doors should be serviced by a qualified technician at least every 12 months to avoid malfunctioning and to guarantee trouble-free operation.

### General condition:

- o Visual inspection of the door leaf and runner rail for corrosion
- o Check runner rail attachment, if necessary, retighten fixings
- o Check toothed belts and steel ropes for damages and correct tension

### Runner rail:

- o Clean runner rail
- o Lubricate runner rail and roller track

### Braking system:

- o Check and, if necessary, set hydraulic brake mechanism and shock absorbers

**If malfunctions occur (e.g. stiff door operation, unusual noises during operation, etc.), immediately contact a specialist company to carry out checks.**

## 14. Declaration of Conformity and CE Mark

After operative assembly of the door system (door and, if necessary, drive and/or hold open device), the *door system manufacturer* has to issue an EC Declaration of Conformity (in accordance with Article 8 of the European Directive 89/392/EEC) and present it to the owner for future reference. The door system is additionally provided with a “CE” mark.

**Note:** *Manufacturer of the door system or the hold open device is the installation engineer or the installation company which is in charge of mounting the door system/hold open device, i.e. connecting and assembling the individual components (door and, if necessary, the hold open device and/or electric drive, etc.). It is expressly stated that it is not automatically the door manufacturer or a subcontractor commissioned by the installation company.*

**The Marantec electric drive (type 252) has been designed for approx. 35,000 operating cycles provided that the doors have a leaf area of  $\leq 25\text{m}^2$  and are operated under normal operating conditions - in fully functional condition - without impairments.**

**The Schnetz electric drive (type ATS 300 WST) has been designed for approx. 25,000 operating cycles provided that the doors are operated under normal operating conditions - in fully functional condition - without impairments.**

**Please observe these specifications for future maintenance of power operated doors.**





## Inspection Book for Power Operated Doors

***Teckentrup Multi-Purpose Sliding Doors dw 40 –1/-2 and dw 62-1/-2,***

Door No.: \_\_\_\_\_

Company: \_\_\_\_\_

Site: \_\_\_\_\_

## Basic Principles for the Inspection of Power Operated Doors

The safety technical requirements and test methods for the construction and equipment of power operated doors are specified in the European standard **DIN EN 13241-1 : 2004**, which puts the general requirements of the European Construction Products Directive in concrete terms. Normative references in DIN EN 13241-1: 2004 are especially:

EN 418	Safety of machinery – Emergency stop equipment
DIN EN 12604	Doors and Gates – Mechanical aspects – Requirements
DIN EN 12605	Doors and Gates – Mechanical aspects – Test methods
DIN EN 12453	Doors and Gates – Safety in use of power operated doors – Requirements
DIN EN 12445	Doors and Gates – Safety in use of power operated doors – Test methods
DIN EN 12635	Doors and Gates – Installation and use,
DIN EN 12978	Doors and Gates – Safety devices for power operated doors and gates – Requirements and test methods

The specifications of the “Guideline for Power Operated Windows, Doors and Gates” ZH1/494 are still valid for power operated doors which entered the market before 1 November 2000 or 1 June 2001. The standards do not demand the retrofitting of existing systems which were installed before the aforementioned dates. However, the European standards stated above are valid for all doors without powered operation which have been retrofitted with an electric drive since 1 June 2001.

Power operated doors have to be inspected by a qualified person prior to initial commissioning and as and when required – an inspection should be carried at least once a year. This inspection cannot be equated with maintenance work.

A qualified person is someone who, due to his/her technical training and experience, possesses sufficient knowledge of power operated doors and of the respective official occupational health and safety regulations, directives and generally recognised technical rules (e.g. DIN standards, VDE specifications) to determine the safe condition of doors. This person can be a qualified technician, an authorised employee of the manufacturer, supplier or installation company, or an appropriately experienced employee of the owner.

These specialists have to carry out their assessment impartially based on occupational health and safety regulations. They should not be influenced by any other circumstances, e.g. financial reasons.

The inspection result has to be recorded in writing in an inspection book issued for the respective door. This written documentation should always be kept to hand for future reference at the installation site of the power operated doors.

## System Data

- 1. Name:** Teckentrup **Multi Purpose Sliding Doors** **Type:** dw 40-1/-2, dw 62-1/-2  
 Door No.: \_\_\_\_\_ Year of Construction: \_\_\_\_\_ Commissioned on: \_\_\_\_\_  
 Manufacturer (Installation Company) or Supplier: \_\_\_\_\_

The operator has received instructions about safe operation of the door system

**2. Leaf**

Dimensions: \_\_\_\_\_ Material: Galvanized steel plate

Weight: \_\_\_\_\_

Glazing  no  yes → Specify type of glass: \_\_\_\_\_

**3. Electric Drive**

Automatic version, manufacturer or supplier: Marantec,

Type/Name: CarTeck 252

Output: 260 W

Operating voltage: 230 (V)

Control voltage: 230 (V)

**4. Control**

**Manufacturer: Integrated in the electric drive,**

**Type of control:**

- Pulse operation**
- Deadman**
- Remote control (pulse/deadman)**
- Key switch**
- Induction loop**
- Radar**
- Others:** \_\_\_\_\_

**5. Safety of the main contact edge**

- Safety edge, safety edge mechanism
- Force limitation
- Safety photocell grid
- Others: \_\_\_\_\_

## Inspection List for Power Operated Sliding Doors

### 0. System Data

Name: Teckentrup Steel Multi Purpose Door Type.: **dw 40-1/-2, dw 62-1/-2**

Door No.: \_\_\_\_\_ Year of Construction: \_\_\_\_\_

Commissioning: \_\_\_\_\_

Manufacturer or Supplier: \_\_\_\_\_

OK = In order

Main. = Maintenance necessary

n.a. = not applicable

		OK	Main.	n.a.
<b>1. Leaves, Guides</b>				
1.1	Leaves (fixing / wear)	<input type="checkbox"/>	<input type="checkbox"/>	<input type="checkbox"/>
1.2	Leaf panel (fixing condition)	<input type="checkbox"/>	<input type="checkbox"/>	<input type="checkbox"/>
1.3	Safety edge mechanism (condition / function / distances)	<input type="checkbox"/>	<input type="checkbox"/>	<input type="checkbox"/>
1.4	Gaskets (condition / wear)	<input type="checkbox"/>	<input type="checkbox"/>	<input type="checkbox"/>
1.5	Castor, rollers (fixing / wear / Hinges lubrication)	<input type="checkbox"/>	<input type="checkbox"/>	<input type="checkbox"/>
1.6	Leaf suspension (protection against lifting / derailing)	<input type="checkbox"/>	<input type="checkbox"/>	<input type="checkbox"/>
1.7	Wicket door (locking with the elec. drive)	<input type="checkbox"/>	<input type="checkbox"/>	<input type="checkbox"/>
1.8	Door leaf locking (function)	<input type="checkbox"/>	<input type="checkbox"/>	<input type="checkbox"/>
<b>2. Drive</b>				
2.1	Drive unit and bracket (fixing)	<input type="checkbox"/>	<input type="checkbox"/>	<input type="checkbox"/>
2.2	Gear casing (sealing)	<input type="checkbox"/>	<input type="checkbox"/>	<input type="checkbox"/>
2.3	Lubricant level (amount)	<input type="checkbox"/>	<input type="checkbox"/>	<input type="checkbox"/>
2.4	Braking effect (function)	<input type="checkbox"/>	<input type="checkbox"/>	<input type="checkbox"/>
2.5	Electrical lines and connections (condition)	<input type="checkbox"/>	<input type="checkbox"/>	<input type="checkbox"/>
2.6	Drive chain (lubrication / wear) other transmission	<input type="checkbox"/>	<input type="checkbox"/>	<input type="checkbox"/>
2.7	Chain wheel protection (condition)	<input type="checkbox"/>	<input type="checkbox"/>	<input type="checkbox"/>
2.8	Devices for manual Operation (function)	<input type="checkbox"/>	<input type="checkbox"/>	<input type="checkbox"/>

		OK	Main.	n.a.	
<b>2.9</b>	Overload protection, e.g. slipping clutches, pressure control valve	(function)	<input type="checkbox"/>	<input type="checkbox"/>	<input type="checkbox"/>
<b>2.10</b>	Slowing-down path	(measurement)	<input type="checkbox"/>	<input type="checkbox"/>	<input type="checkbox"/>
<b>3.</b>	<b>Control</b>				
<b>3.1</b>	Controls (push buttons, deadman control)	(function)	<input type="checkbox"/>	<input type="checkbox"/>	<input type="checkbox"/>
<b>3.2</b>	Limit switch, emergency limit switch	(function)	<input type="checkbox"/>	<input type="checkbox"/>	<input type="checkbox"/>
<b>3.3</b>	Main switch	(function)	<input type="checkbox"/>	<input type="checkbox"/>	<input type="checkbox"/>
<b>3.4</b>	Devices for Remote control, including Emergency off device	(function)	<input type="checkbox"/>	<input type="checkbox"/>	<input type="checkbox"/>
<b>3.5</b>	Protective motor switch	(function)	<input type="checkbox"/>	<input type="checkbox"/>	<input type="checkbox"/>
<b>4.</b>	<b>Devices for securing pinch and shearing points</b>				
<b>4.1</b>	Safety edge	(function)	<input type="checkbox"/>	<input type="checkbox"/>	<input type="checkbox"/>
<b>4.2</b>	Force limitation	(function)	<input type="checkbox"/>	<input type="checkbox"/>	<input type="checkbox"/>
<b>4.3</b>	Deadman control	(function)	<input type="checkbox"/>	<input type="checkbox"/>	<input type="checkbox"/>
<b>4.4</b>	Contact-free functioning protective devices	(function)	<input type="checkbox"/>	<input type="checkbox"/>	<input type="checkbox"/>
<b>4.5</b>	Clearance between leaves and fixed parts in the vicinity	(function, measurement)	<input type="checkbox"/>	<input type="checkbox"/>	<input type="checkbox"/>
<b>4.6</b>	Contact mats	(function)	<input type="checkbox"/>	<input type="checkbox"/>	<input type="checkbox"/>
<b>4.7</b>	Radar devices in combination with safety photocells	(function)	<input type="checkbox"/>	<input type="checkbox"/>	<input type="checkbox"/>
<b>4.8</b>	Covers	(function)	<input type="checkbox"/>	<input type="checkbox"/>	<input type="checkbox"/>
<b>4.9</b>	Closing speed of automatic closing doors $\leq 0.3\text{m/s}$	(function)	<input type="checkbox"/>	<input type="checkbox"/>	<input type="checkbox"/>
<b>4.10</b>	Acoustic warning device of automatic closing doors speed $>0.3\text{m/s}$	(function)	<input type="checkbox"/>	<input type="checkbox"/>	<input type="checkbox"/>



	OK	Main.	n.a.
<b>5. Markings</b>			
5.1 Sliding door, folding door (complete, legibility)	<input type="checkbox"/>	<input type="checkbox"/>	<input type="checkbox"/>
manufacturer or supplier,			
year of construction, factory no.,			
licence no.			
CE marking (from 01.01.1997)			

**6. Inspection findings and required measures <sup>1)</sup> (if necessary supplementary sheet):**

---

---

---

---

---

---

---

---

<sup>1)</sup> If the door system is not OK, not operationally reliable, description of the chosen compensatory safety measures.

**The customer / operator has been recommended to place the door system out of service:**

on: \_\_\_\_\_ Name (Operator): \_\_\_\_\_

Date: \_\_\_\_\_ Signature: \_\_\_\_\_ Company: \_\_\_\_\_

Date of next inspection: \_\_\_\_\_

**7. Defects eliminated – operating and functional safety guaranteed**

Date: \_\_\_\_\_ Signature: \_\_\_\_\_

Company: \_\_\_\_\_