



Before You Start...

PLEASE READ THE INSTRUCTIONS THROUGH THOROUGHLY BEFORE INSTALLING. FAILURE TO FOLLOW THE INSTRUCTION WILL VOID THE PRODUCT GUARANTEES AND MAY RESULT IN PERSONAL INJURY.

- This garage door is intended for domestic use only.
- Garage doors are heavy and require appropriate handling. Always wear gloves to protect hands from any sharp edges.
- Do not attempt to install the door if you are unsure of any part of the instructions in this booklet.
- For advice contact Teckentrup on: 01925 924 050

Door Packaging

Doors are supplied fully assembled. Double leaf doors stays are fixed to the door leaves but will require fixing to the frame head. All doors are shipped upside down. Doors with a standard threshold also have a transit strip between the frame legs that should be removed prior to installation. Doors with a raised threshold do not have a transit strip.

Check the delivery notification to confirm sizes are as expected. Remove all protective packaging before installation. The packaging can be used to protect the door when it is laid flat to remove the door leaves.

Single & Double Leaf Doors

These instructions are suitable for single and double leaf doors.

Any differences in procedure are highlighted where they occur

Tools You Will Need

- Spirit or laser levels
- Drill & bits for fixing holes and shoot bolt keeps
- Pozidrive screw driver
- Allen key set
- Adjustable spanner
- Spacers/wedges for frame setting
- Cleaning materials

Fixings

The fixing pack supplied contains:
6no. fixing straps (Used when through the frame fixings cannot be made)
6no. 8x60 screws and plugs
6no. 8/92 expansion fixings



The Opening

The opening in which the door is to be fitted should be in a suitable condition. For stability and long service life, adequate site work is essential.

The opening must be formed from materials of adequate strength and all brick or concrete. Block work should ideally be a minimum of 15N/mm².

Aerated concrete is not recommended and hollow bricks/blocks should be suitably back-filled during opening construction to provide strength for the frame fixing bolts.

Where doors are to be installed into low density block work (7N/mm²) additional fixings may be required to ensure stability.

Openings must be plumb and square and the floor area within the arc swept by the door leaf must be level or fall away from the opening.

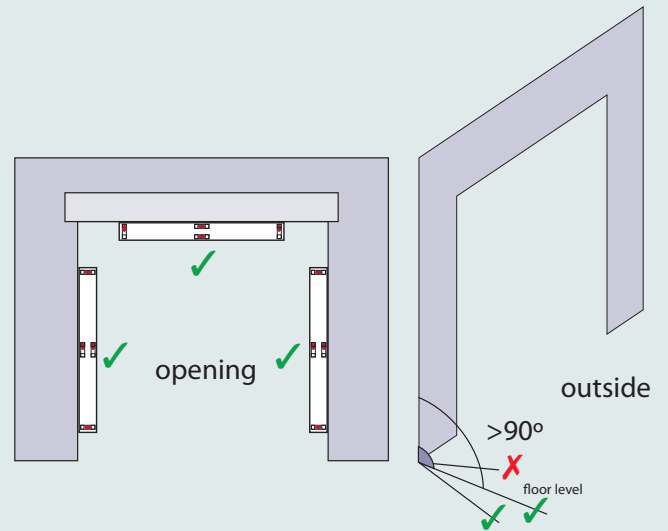

The threshold must be flat/level and sound across the full width of the opening.

1

Lay the complete door and frame flat with the outer face uppermost (the hinged face) and the frame head towards the door opening. Ensure the frame is protected from abrasion by contact with the floor surface.

Remove the door leaves or leaf (personnel doors) by lifting them off their hinges with an upwards motion (toward the frame header). Set aside the doors leaves and ensure they are secured from falling.

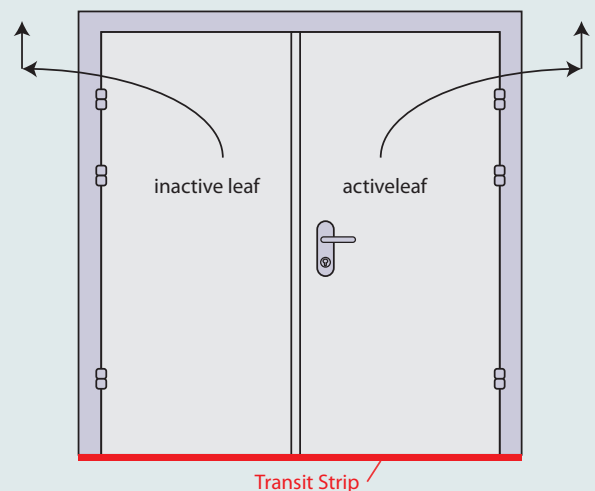

2

Remove the transit strip from the bottom of the frame legs. Position the frame in the opening. Position the frame at the front edge of the opening rebate. The frame can be positioned as required on the rebate, however care must be taken on deep rebates to protect the door leaf from striking the rebate if the door is allowed to open beyond 90°. If a threshold is being fitted ensure this is correctly positioned at the foot of the frame legs. Do not fix the threshold until the door is correctly hung.

Ensure the frame legs are plumb. If the frame head is not level, use a packing wedge to raise one of the frame legs (A) until the header is level. Wedge the frame in position, ready for fixing.

Check the diagonals to ensure all is square.

Remove the cover grommets from the inactive leaf frame leg (hinge side on single leaf doors) and drill through into the opening block work. Fix the inactive leaf frame leg with suitable fixings. Do not refit the cover grommets in-case adjustment is required. The supplied fixing straps can be used if fixing through the frame cannot be achieved.

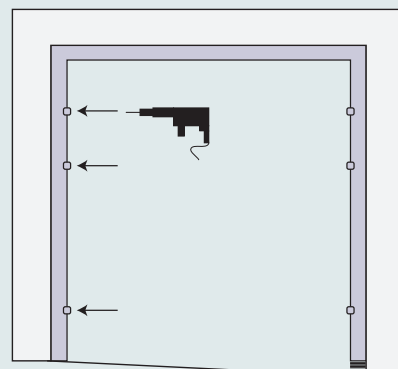
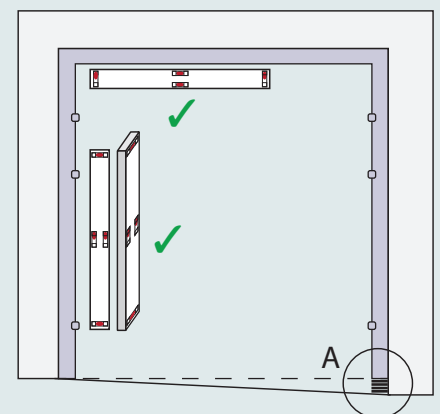

When drilling ensure all parts of the door are protected from brick dust and other fragments.

- 3 Re-hang the inactive door leaf (the door leaf on personnel doors), ensure it swings cleanly and then secure in the closed position with the top shoot bolt. If the throw of the shoot bolt requires adjusting unscrew the lock and adjust with the threaded rod/bolt to the desired length (C). For single leaf doors the swing should be checked and the door wedged in the open position.

Remove the cover grommets from the active leaf frame leg (locking side on single leaf doors) and drill through into the opening block work. Fix the active leaf frame leg with suitable fixings. Do not refit the cover grommets in-case adjustment is required.

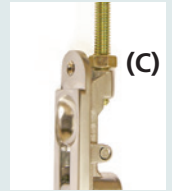
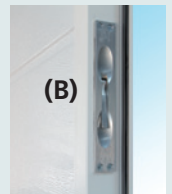
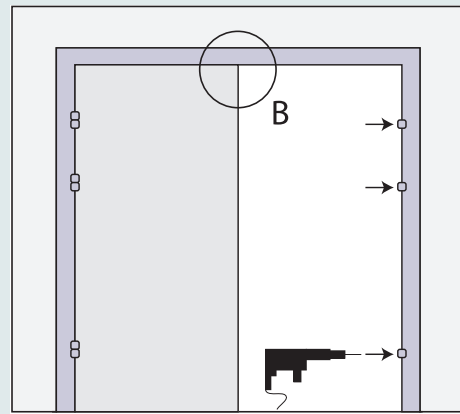

- 4 Re-hang the active door leaf, ensure it swings cleanly and check alignment of door leaf in the closed position.

Small adjustments can be made using the hinges (see below), however adjusting the alignment of the frame legs is the preferred method for ensuring the correct position of the door leaves. Any slight misalignment at the frame leg is "magnified" at the door edge. 0.5mm out of true may show as several mm at the doors leading edge or level. Adjustment should be made by moving the frame leg in the planes as noted in 'D' and 'E'. Small changes in plane 'D' will align the door edge vertically, whilst small changes in plane 'E' will align the leaf horizontally. A combination of both should provide the correct alignment. Movements in plane 'E' may require packing shims to maintain the position (not supplied) Both sides of the frame may require adjustment. Open the door leaf, make the adjustments and close to check the door is hanging true.

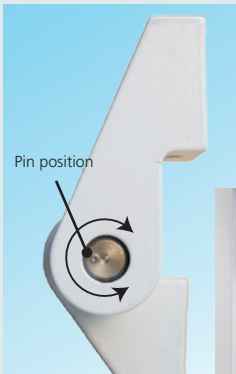
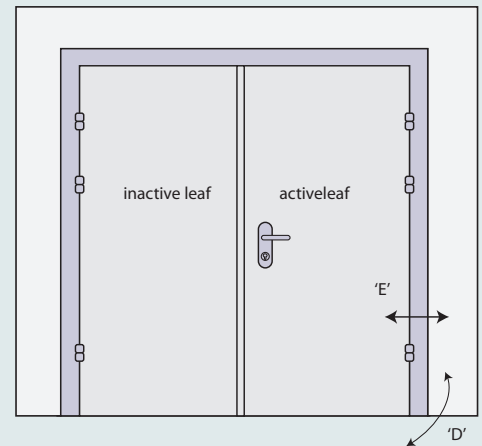

The hinge pin and polymer hinge bearing are both acentric and allow for +/- 0.75mm adjustment each to the hinge position. The dot on the top of the pin shows its position and this can be adjusted with an allen key inserted into the bottom of the pin (release the grub screw in the hinge to allow adjustment).



The polymer hinge bearing can be aligned in one of four positions - remove the door leaf, unseat the bearing and rotate to the desired position (see right). The hinge pin can also be adjusted - see below.



Once all adjustments are complete, fit the cover grommets to the fixing holes in the frame.

Hinge Pin Adjustment

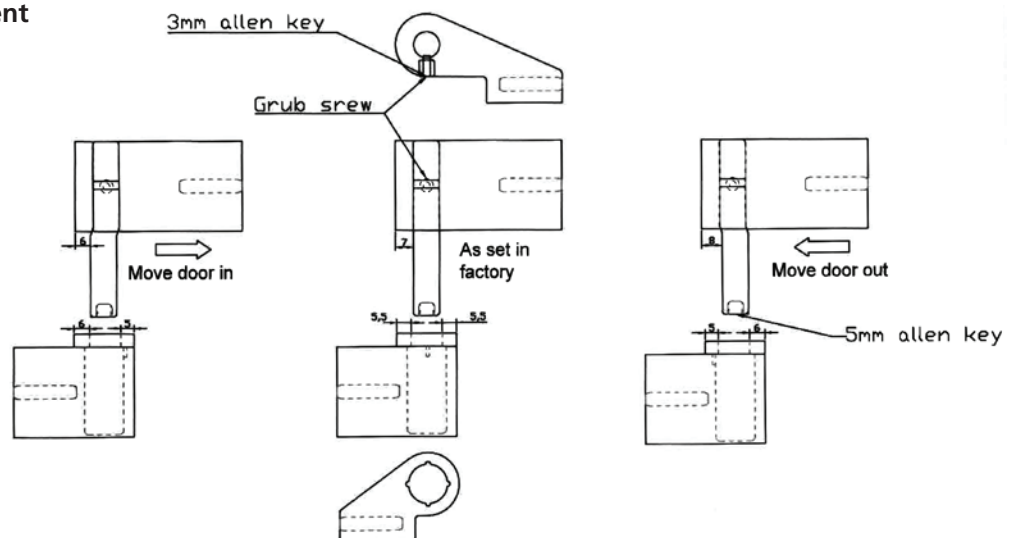

5

When the door is hanging correctly, check the lock keeps for alignment with the lock mortise and latch. Extending of the vertical length of the lock keeps may be required to allow a clean engagement of the mortise/latch.

With the door correctly hung, fix the threshold in place and drill a keep (12mm dia.) for the bottom shoot bolt on the inactive leaf. To adjust the throw of the bolt see section 3. A floor that is not level/flat across the full width of the opening will require packing to ensure correct installation of the threshold.

Attach the door stay arms to the frame head (not supplied on personnel doors) using the self tapping screws provided and the pre-drilled holes. Check operation to ensure the stays engage and disengage and the door leaves do not strike the opening reveal.



6

Clean and dry the door thoroughly inside and out with warm soapy water to remove any grease, dust and metal fragments from the door (these may discolour the door finish if left on the door).

The door is now installed and should operate smoothly. The door is supplied with 3 keys for the lock and these, along with the fitting instructions should be given to the end-user on handover.

Operation and future adjustment.

The door should always be opened active leaf first, inactive leaf second to the fully opened position with the stays engaged. "Throwing" the leaf open will result in potential damage to the door leaf and stays. The inactive leaf must always be secured with the top and bottom shoot bolts located to ensure correct alignment of the door leaf and a secure closure.

No lubrication of the hinges is required, however a light spray oil should periodically be applied to the door stay mechanism. Alignment of the leaves can be adjusted using the procedure in section 4.

Teckentrup UK Limited, Units 2-4, Opus 9 Industrial Estate,
Woburn Road, Winwick Quay, Warrington WA2 8UE

www.teckentrup.co.uk

t: 01925 924 050 f: 08701 314 843

e: sales@teckentrup.co.uk



Raising Standards
Safety Assured

Member



CONTRACTORS HEALTH & SAFETY ASSESSMENT SCHEME
Accredited Contractor

www.chas.co.uk



August 2018. As ours is a policy of progressive design, we reserve the right to alter specification without prior notice. Errors and omissions excepted.

WWW.TECKENTRUP.CO.UK

TECKENTRUP
DOOR SOLUTIONS