

FITTING INSTRUCTIONS

Side Hinged Garage Doors & Side Doors GSW 40-L

MAY 2026



Scan the qr code to
watch a step by step
fitting video.



 Scan the qr code to watch the fitting videos!

SINGLE & DOUBLE LEAF DOORS...

These instructions are suitable for single and double leaf doors. Any differences in procedure are highlighted where they occur.

Scan the qr code to watch the full step by step fitting video.



BEFORE YOU START...



PLEASE READ THE INSTRUCTIONS THROUGH THOROUGHLY BEFORE INSTALLING. FAILURE TO FOLLOW THE INSTRUCTIONS WILL VOID THE PRODUCT GUARANTEES AND MAY RESULT IN PERSONAL INJURY.

Before you start



- This garage door is intended for domestic use only.
- Installation is a 2-person job.
- Wear suitable PPE! Safety shoes, eye protection for drilling, etc. Garage doors are heavy and require appropriate handling. Always wear gloves to protect hands from any sharp edges.
- Do not attempt to install the door if you are unsure of any part of the instructions in this booklet.
- For advice contact Teckentrup on: **01925 924 050**

TOOLS YOU WILL NEED...

- Spirit or laser levels - **IMPORTANT: laser levels are the recommended device as they are a precision instrument, effective when used in site conditions typical to a garage door opening aperture.**
- Drill and 6mm drill bit for drilling pilot holes for the multi-purpose fixings
- T40 Torx driver for the multi-purpose fixings
- Pozidrive screw driver
- Allen key set including a 4mm for frame lug setting
- Torque wrench with T25 Torx adapter to adjust the hinges
- 4 x wind bags for frame setting & door leaf support
- Spacers/wedges for frame setting (if the wind-out lugs cannot set the frame as required)
- Cleaning materials - car shampoo or similar (do not use turpentine or solvent)

Laser level does the job best!



WHAT'S INSIDE THE FIXING PACK...

The fixing pack supplied contains:

- 12no. multi purpose fixings
- 6no. fixing straps (Used when through the frame fixings cannot be made)
- 1no. pair of handles & fixings
- 2no. door stay arms
- 2no. grease sachets
- 3no. keys
- Fixing hole cover grommets



What's inside the fixing pack box?

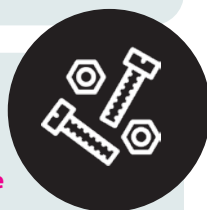



THE OPENING...

Before unpacking the door, check the opening! Does the door size ordered fit?

Check the delivery notification to confirm sizes are as expected.

The opening in which the door is to be fitted should be in a suitable condition. For stability and long service life, adequate site work is essential.

The opening must be formed from materials of adequate strength and all brick or concrete. Block work should ideally be a minimum of 15N/mm².

Aerated concrete is not recommended and hollow bricks/blocks should be suitably back-filled during opening construction to provide strength for the frame fixing bolts.

Where doors are to be installed into low density block work (7N/mm²) additional fixings may be required to ensure stability.

Openings must be plumb and square and the floor area within the arc swept by the door leaf must be level or fall away from the opening.

The threshold must be flat/level and sound across the full width of the opening. A level or sloping threshold will be susceptible to water pooling that will run into the garage. You should consider a floor rebate and drainage channel in front of the door to mitigate water ingress.

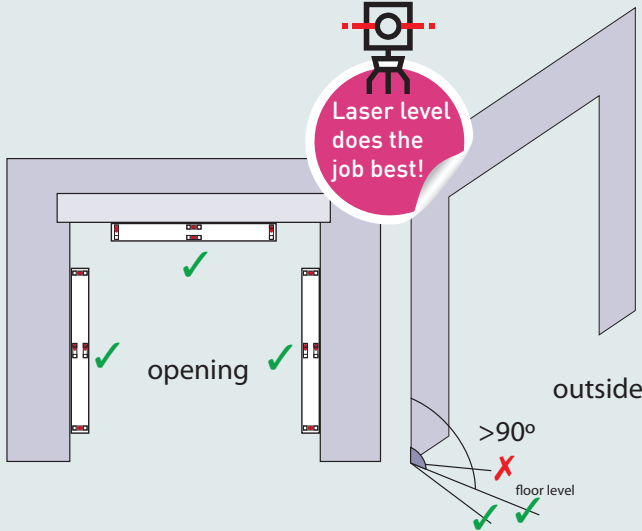

DOOR PACKING...

Check the packaging for signs of damage. Doors are shipped fully assembled and just require the attachment of the lever handles, positioning of the threshold & linking up of the stay arms to the frame head.

Doors with the standard 3-part aluminium threshold do not have a transit strip. Doors ordered with the optional aluminium strip threshold have a transit strip between the frame legs that should be removed prior to installation.



YOU'RE READY TO BEGIN INSTALLING...





1. UNPACKING THE DOOR

 **Doors over 3188mm wide are supplied as a loose frame and door leaves. You will need to assemble the frame and threshold before continuing with the next steps. See page 14 for instructions.**

Lay the complete door and frame flat with the outer face uppermost (the hinged face) and the frame head towards the door opening.

 **Ensure the frame is protected from abrasion by contact with the timbers surface.**

Carefully unpack the door.  **Do not use a blade or sharp edge!**

2. FIT THE DOOR HANDLE

Lift and support the door.

Use the tumb turn to unlock and release the latch to open the door.

Insert the spindle and slide on the handle, ensuring the logo on each handle is facing up (failure to orientate the handles correctly will prevent the handles correctly operating the latch).

Locate and secure the handle roses with the screws provided, ensuring the two holes without nutserts have the female receivers fitted on the external face of the door to prevent unauthorised removal of the handle. Secure by tightening the grub screw and check both handles operates the latch.

To finish, fit the rose covers.

Fitting the
lever handle



3. BEFORE YOU PUT THE DOOR IN THE OPENING

The two ramped parts of the 3-part threshold are taped to the top of the door. Undo the tape and remove both sections before installation.

 **If you've ordered a door with an aluminium strip threshold in place of the standard, remove the transit strip prior to installation. To do this, undo the transit angle screws shown right and remove the transit angle.**



Remove!

Removing the
threshold &
lifting straps



Next, once you've positioned the door near the opening, ensuring it is properly supported, remove the lifting straps using a 10mm hex socket.

Using a drill with a Phillips head, loosen the jacking bolts slightly. The doors' jacking bolts are situated up the side of the frame.

With this step completed, you can position the door in the opening.

Position the frame to the front edge of the opening rebate. The frame can be positioned as required on the rebate, however care must be taken on deep rebates to protect the door leaf from striking the rebate if the door is allowed to open beyond 90°.

Loosening the door
jacking bolts

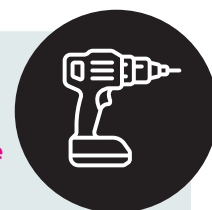

4.

FITTING THE THRESHOLD

On doors with a three part threshold, fit the internal and external threshold ramps. Before fitting the ramps, a suitable mastic/sealant can be applied to the front and back of the threshold to aid weather performance. Check that the seal is not caught or folded to ensure the best seal.

The longer length is fitted on the external side of the door, the shorter length on the internal side of the door.

Angle the door backwards in the opening, slide the front section of the threshold under the fixed section of the threshold until it is interlocked along its full length. Angle the door back to the upright position. Repeat for the back section of the threshold by angling the door forward.

Fitting the 3 part threshold



A floor that is not level/flat across the full width of the opening will require packing to ensure correct installation of the threshold. If the threshold is not level or distorted, the alignment of the leaves with the seal will be compromised and weather performance degraded.



Fixing the threshold on uneven floors



If the threshold is installed on a level surface, to mitigate against pooling of water and potential ingress, wedge the centre strip of the threshold slightly falling from back to the front. This should help the water run away from the door.

Standard 3-Part Threshold

Inside

Outside

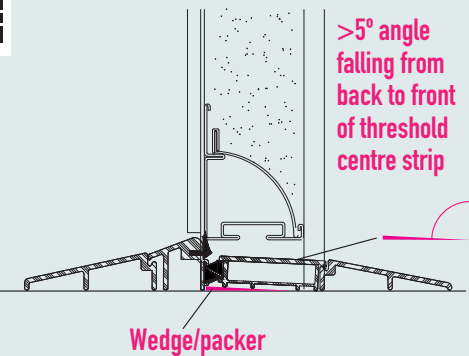

If your door has the aluminium strip threshold, this should be positioned onto a layer of suitable mastic/sealant. Fix the threshold in place in at least four points with screws/plugs and drill a keep for the bottom shoot bolt on the inactive leaf to engage into.



Doors with a strip threshold have a blade seal to the bottom of the doors' leaves. The tip of the seal should be in contact with the threshold when fully closed. If it is not in contact, raise the threshold with a suitable packer along its full length to ensure the threshold is level and undistorted.

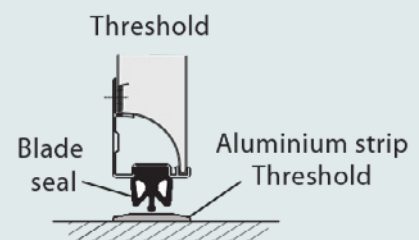



5.

ADJUSTING THE JACK BOLTS AND LEVELLING THE FRAME

Secure the door in position by using a windbag either side of the door between the opening and the door frame. Applying a small amount of pressure to the windbag will hold the door safely in place.

Open both the door leaves and using a windbag under each leaf, secure the doors leaves in the open position ensuring they don't move and are protected. This allows access to the jacking bolts on the inside of the door frame.

Next, level the frame. The preferred method is by using a laser level but you can use a spirit level.

Adjusting the jacking bolts & levelling the frame



Ensure the frame legs are plumb and the header is level. If you need to raise one of the frame legs (**A**) to level the header, this is because your threshold is not level. If packers or the wind-out lugs are used to raise a frame leg, **the threshold must be supported across its full length**. Use the windbags to adjust and manoeuvre the frame within the opening.



Laser level does the job best!

Then, use the wind-out lugs (jacking bolts) as shown on the facing page to position and hold the door securely in the opening. **Do not fix at this stage!**

Shown without door leaves for clarity

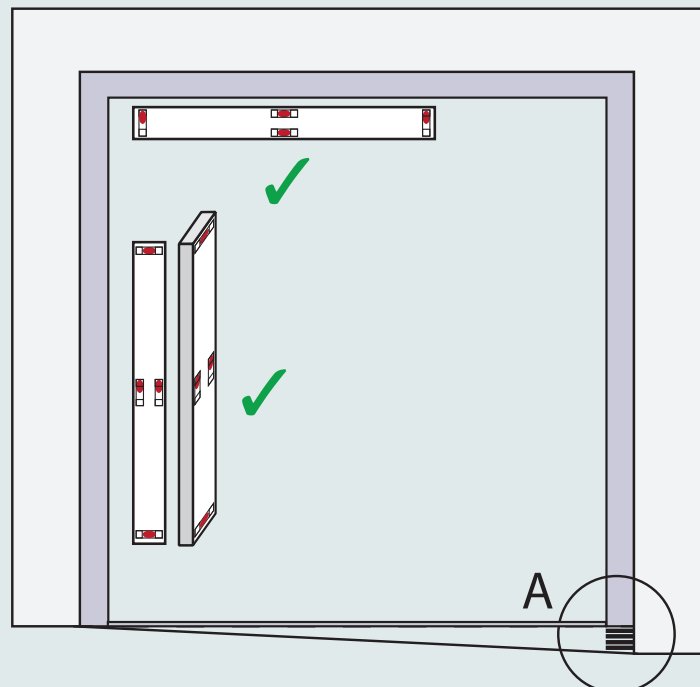

The standard threshold should not require fixings when sited on a level and smooth threshold. The optional aluminium strip threshold will require fixings, but do not fix until the door is correctly hung. Ensure fixings do not distort the threshold as this will compromise the closure of the door and the engagement of the seals.



2 lugs at each of the four fixing points per side.



Lugs are accessed through the frame fixing hole.

Wind out all lugs using a 4mm allen key. **Failure to do this will result in frame twist and distortion when fixing are tightened.**

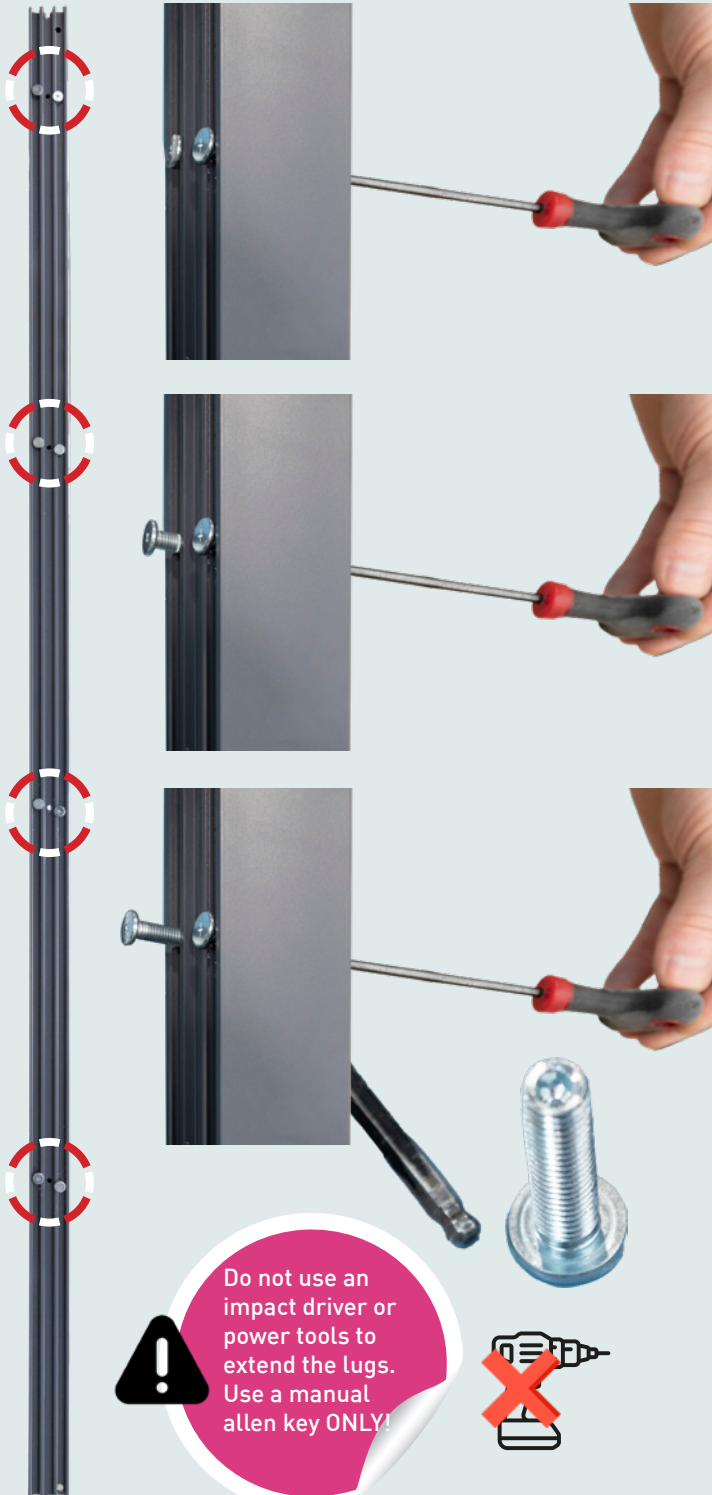

Do not use an impact driver or power tools to extend the lugs. Use a manual allen key ONLY!

If the pillars are not square use the wind-out lugs to ensure the frame is set at 90°.

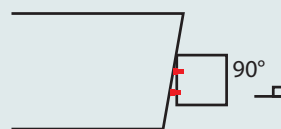

If the opening pillars are out of line, ensure the frame is not distorted.

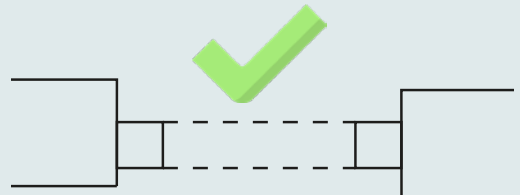
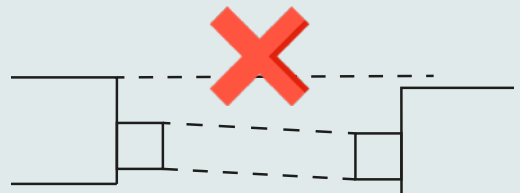



6. ADJUSTING THE DOOR LEAVES

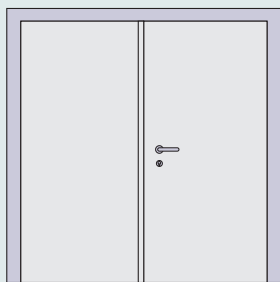

When the frame is set, close the door leaves and check alignment.



The top edges of each leaf should be horizontal and level with each other.



The door leaves also need to align vertically with the leading edges of each leaf aligned along their full length.



If adjustment of door leaf alignment is required, manipulation of the frame setting is often sufficient to correct misalignment. Follow the guidance below.

Spirit levels and even laser levels may show that the frame is well set and true, however over the length of the frame, even a slight variance at the frame is magnified at the door edge. 0.5mm out of true may show as several mm at the doors' leading edge or level.

Adjustment should be made by moving the frame leg in the planes as noted in 'D' and 'E'. Small changes in plane 'D' at the top or bottom of the frame will align the door edge vertically, whilst small changes in plane 'E' will align the leaf horizontally. Wind bags can be used to manipulate the frame by adding pressure to one side of the frame and then adjusting the jacking bolts to hold the position.

A combination of both will often provide the correct alignment. Both sides of the frame may require adjustment. This can be achieved by inserting a wind bag and pumping until the leaves are level.

Open the door leaf, make the adjustments to the jacking bolts and close to check the door is hanging true.

Adjusting the door leaves

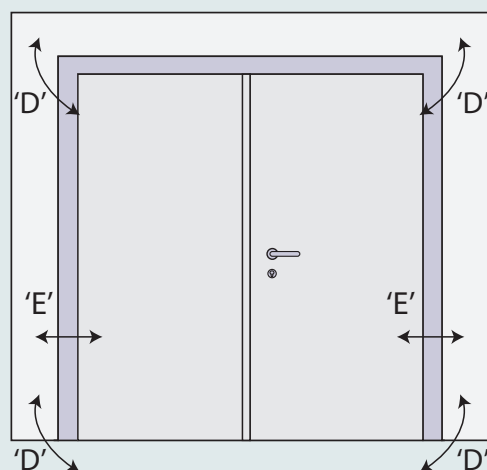

If, after following the above guidance, further alignment is required, use the hinge adjustment to correct the leaf alignment.



HINGE ADJUSTMENT

! See page 15 for adjustment of surface mounted hinges - this includes doors over 3188mm wide.

Hinges can be adjusted vertically and horizontally in the plane of the edge to edge of the leaf.

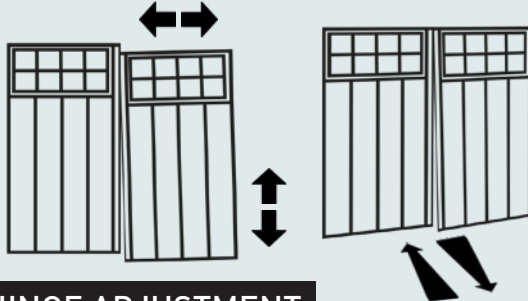

Scan the qr code to watch a short film on how to adjust hinges.

VERTICAL HINGE ADJUSTMENT



Use a T25 Torx to loosen these two screws to allow the leaf to move up and down in the frame profile, then tighten.

! All hinges may require adjustment.



LEAF-TO-FRAME CLEARANCE

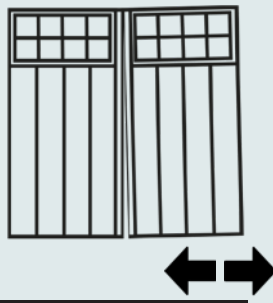

Use a T25 Torx to loosen these two screws, align using the slotted hole, then tighten.

! All hinges may require adjustment.

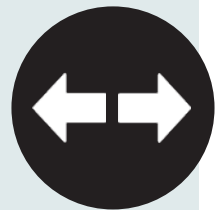

GASKET CLAMPING FORCE ADJUSTMENT



Use a T25 Torx to loosen these two screws, align using the slotted hole, then tighten.

! All hinges may require adjustment.

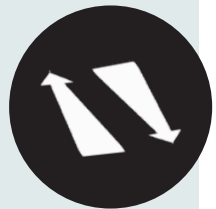

! After adjustment of the hinges is complete, tighten the securing screws with a torque wrench to 8.5Nm torque.

 Scan the qr code to watch the fitting videos!



7. FIXING THE FRAME

Drill a 6mm pilot hole for each fixing point. Secure the frame using the multi-purpose fixings provided using a T40 Torx head driver. Multi-purpose fixings do not require wall plugs and can be driven straight into the pilot hole. They are suitable for brick, concrete and timber.

Fixing the frame



When drilling ensure all parts of the door are protected from brick dust and other fragments.

The supplied fixing straps can be used if fixing through the frame cannot be achieved.

We recommend a fixing at each hinge and one additional point on the frame legs and two into the header as shown below, as a minimum. Wider doors may require an additional fixing through the header. This fixing can be made by removing the central plate and fixing through. This will stop any kind of deflection.

 If you're using an impact driver, do not over tighten - it will distort the frame!

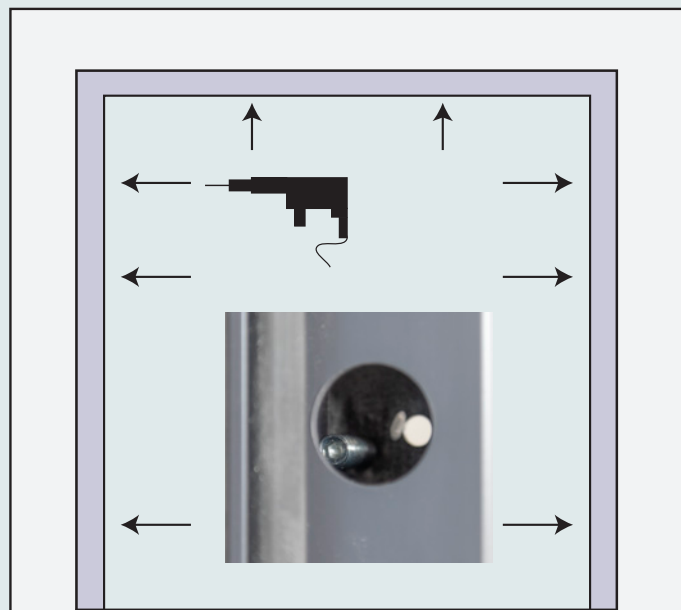

Do not fit the cover grommets in-case adjustment is required.

After each fixing check the door alignment has not shifted and the frame has not been distorted.



If packers have been used, ensure each fixing point has packers to prevent the frame distorting when tightening fixings.

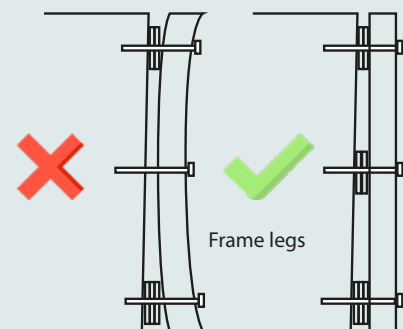
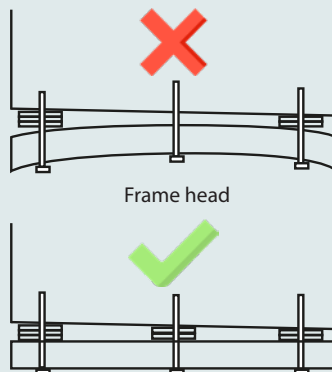

8. ADJUSTING THE SHOOT BOLT KEEPS (DOUBLE DOORS ONLY)

If the shoot bolts on the inactive leaf do not hold the door leaf against the seal, the top (all doors) and bottom (not applicable to the aluminium strip threshold) shoot bolt keep can be adjusted.

Start by loosening the screws either side of the plate.

Slide the keep plate to move the bolt location point in or out until a snug fit is achieved.

After adjustment is complete, re-tighten the screws. Repeat the process, if needed, at the top of the door.

Adjusting the flush bolt plate



9. ADJUSTING THE STRIKE PLATE AND KEEPS

When the door is hanging correctly, check the lock keeps for alignment with the lock mortise and latch. If there is too much play in the latching, use the adjusters directly above and below the latch keep to move the latch point for a snug fit when the door is closed.

The standard lever handle strike plate uses cams to adjust the position.

Using a flat head screwdriver, turn the cams at the top and bottom until the strike plate is in the desired position.

Strike plates on doors without lever handles are adjusted by loosening the screws at the top and bottom of the plate and moving the keep by hand.

To finish once adjusted, tighten the screws.

Adjusting the strike plate & keeps



Standard lock



3-point lock

With the three point locking, there are keeps at the top and bottom of the door. These keeps are machined slightly off centre which allows a tighter seal should you require it.

Simply take the plate off, turn it around 180° and refit it.



 Scan the qr code to watch the fitting videos!



10. FITTING THE STAYS

Included with every door is a sachet of lubricating grease to be applied to the rail, spring and slider of each door stay. Alternatively, white lithium grease can be used.



Fitting the door stay and grommets



 **Although the grease is a special formula that won't stain the door leaf, should grease contact the door, ensure it is cleaned off prior to handover.**

With the door aligned and latching, open the door leaf and apply a generous amount of grease to where the stay arm runs.

Next slide in the spring-loaded stay arms (not supplied on personnel doors or leaves on double doors that are under 780mm wide) and attach using the self tapping screws provided and the pre-drilled holes.

 **Check operation to ensure the stays engage and disengage and the door leaves do not strike the opening reveal.**

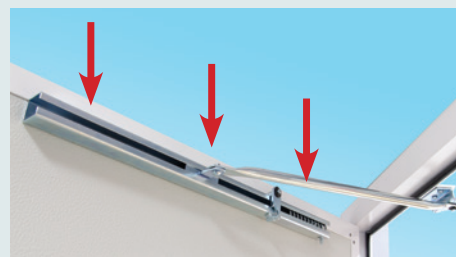

10. FITTING THE STAYS GROMMETS & CLEANING



To finish, check the function of the door and locks now everything is in place and that compression seals are not caught or folded to ensure the best seal.

Fit the grommets to cover the fixing holes.

Clean and dry the door thoroughly inside and out with warm soapy water to remove any grease, dust and metal fragments from the door (these will discolour the door finish if left on the door).

The door is now installed and should operate smoothly.

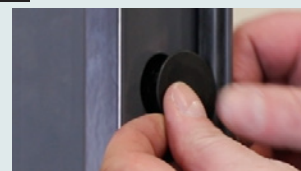

After installation cleaning



Door labels



Security keys



 **The door is supplied with 3 keys for the lock and these, along with the fitting instructions should be given to the end-user on handover.**



11. TRIMMING UP

Concealed hinges make trimming up simple. If your trim overlaps onto the frame, ensure it is <math><10\text{mm}</math> thick. Trim thicker than 10mm will foul the arc of the door leaf preventing full opening.

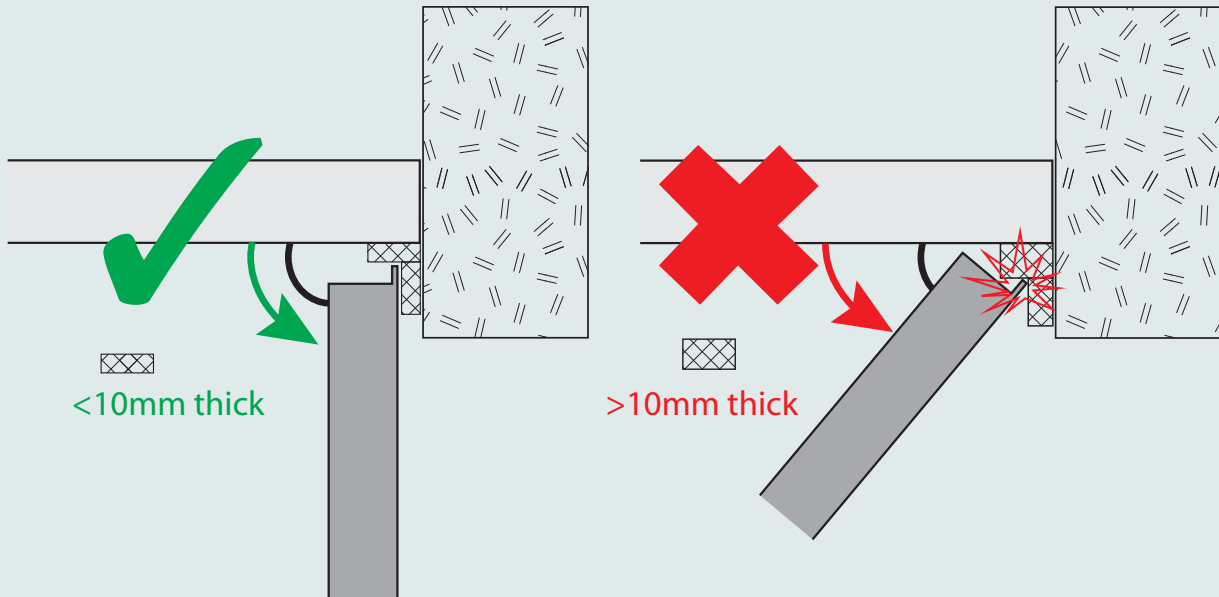

OPERATION & FUTURE ADJUSTMENT



The door should always be opened active leaf first, inactive leaf second to the fully opened position with the stays engaged.

“Throwing” the leaf open will result in potential damage to the door leaf and stays.

 The inactive leaf must always be secured with the top and bottom shoot bolts located to ensure correct alignment of the door leaf and a secure closure.

No lubrication of the hinges is required, however a light spray oil should periodically be applied to the door stay mechanism. Alignment of the leaves can be adjusted using the procedure in section 4.



Frame & threshold assembly



FOR DOORS OVER 3188MM IN WIDTH

FRAME & THRESHOLD ASSEMBLY PROCEDURE

To assemble the frame, slide the magic corner into the guides on the frame and header, pushing the profiles together.

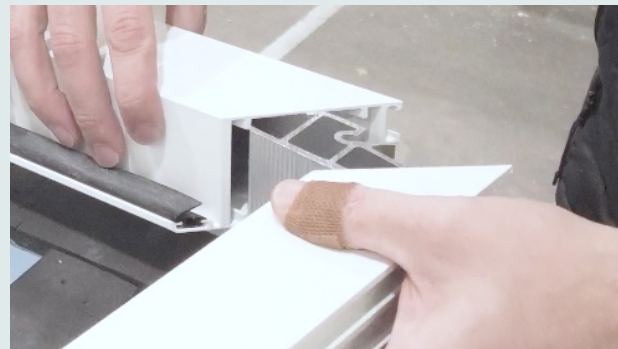

Through the small slot in the frame, use an allen key to tighten. As you tighten, the frame will pull together.

 **Adjust positioning as you tighten to ensure alignment is level.**

Repeat on the other corner.

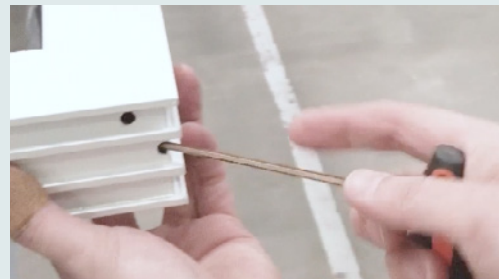

Next, position the threshold at the foot of the frame. Align the threshold with the pre-drilled hole in the frame with the rubber strip to the back of the frame. Using the screws provided, secure.

Repeat on the other side.



To finish, hang the door leaves.

RETURN TO STEP 1 ONCE ASSEMBLY IS COMPLETE

FOR DOORS WITH SURFACE MOUNTED HINGES

HINGE ADJUSTMENT

Hinges can be adjusted vertically and horizontally in the plane of the edge to edge of the leaf.

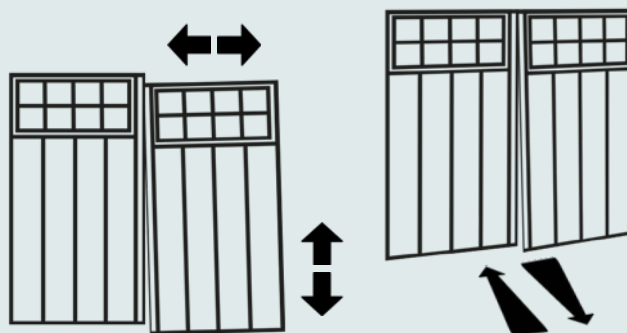

VERTICAL HINGE ADJUSTMENT

The hinges are set to their lowest point for vertical alignment, allowing the hinges to be raised by up to 4mm.

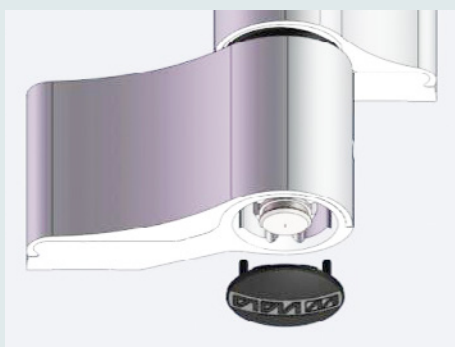
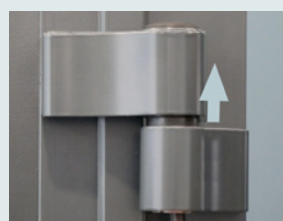

1. Remove the bottom plug.

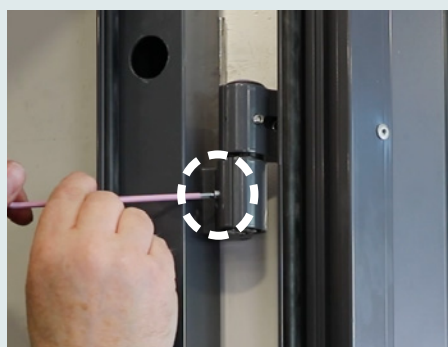

2. Open the door, loosen the M6x5 set screw (4mm allen key).

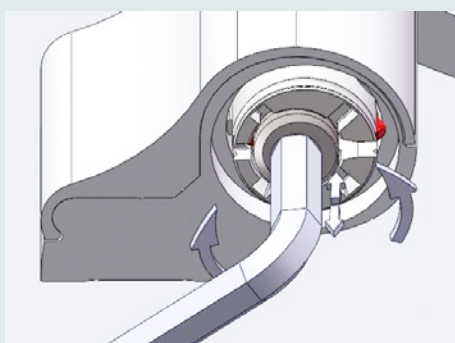

3. Close the door and use the M12 set screw (6mm allen key) to adjust.

An adjustment of up to 4mm is possible.

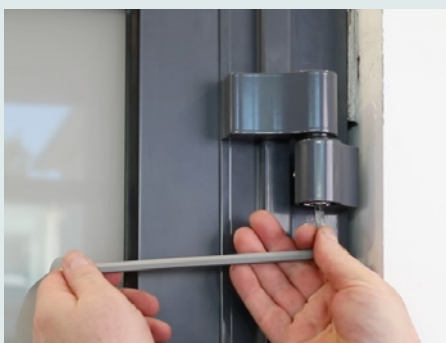

4. After adjustment, re-tighten the M6x5 set screw (4mm allen key) and refit the plug.

Surface mounted hinge adjustment



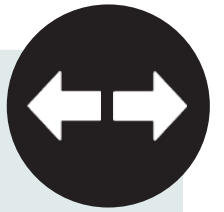

LEAF-TO-FRAME CLEARANCE

The hinges are set to the mid-point for the horizontal position in the leaf edge to leaf edge plane of the door leaf, allowing for + or - 3.1mm of adjustment. This allows the door leaf to be made level.

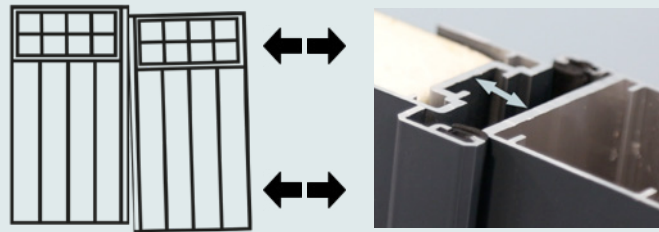

1. Remove the top plug.

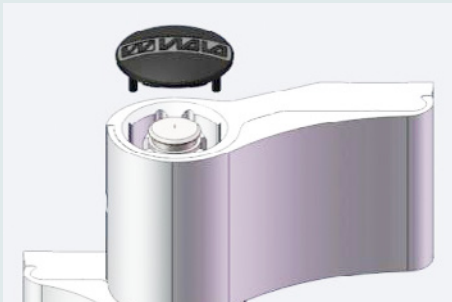

2. Open the door, remove the M4 screw (3mm allen key).



 Do not attempt to remove the hinge cover without releasing the set screw. Damage will occur!

3. Loosen the M6x5 set screw (4mm allen key).

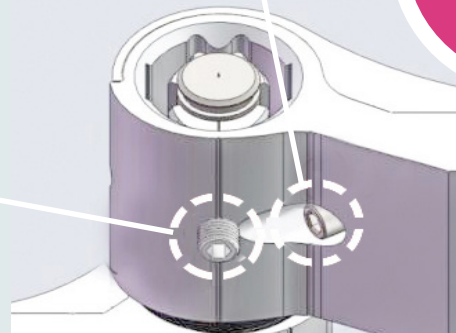
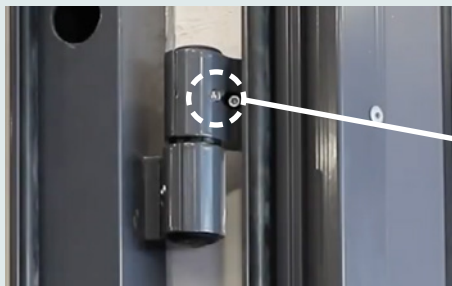

4. Close the door, remove the hinge cover and adjust.

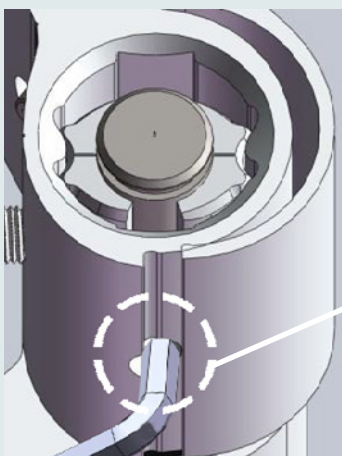

Surface mounted hinge adjustment



Adjustment options for leaf-to-leaf:

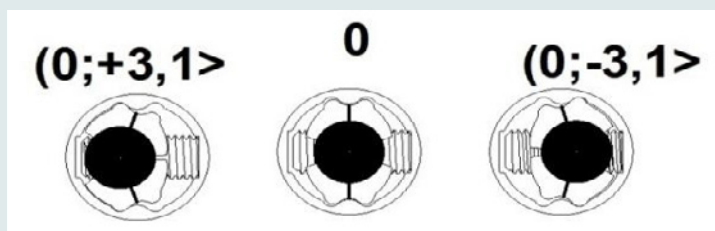

5. After adjustment, refit covers, insert and tighten the M4 screw (3mm allen key), re-tighten the M6x5 set screw (4mm allen key) and refit the plug.



GASKET CLAMPING FORCE ADJUSTMENT

The hinges are set to the mid-point (0) for the horizontal position in the outer leaf-face to inner leaf-face plane of the door leaf. There are two selectable positions in each direction - see below.

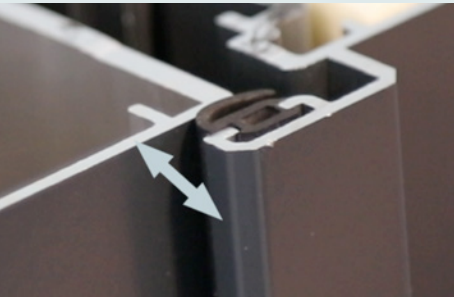

Surface mounted hinge adjustment



1. Remove the bottom plug.



3. Open the door, loosen the M6x5 set screw (4mm allen key).



2. Close the door and remove the M12 set screw .



4. Insert the door key head and turn to adjust.

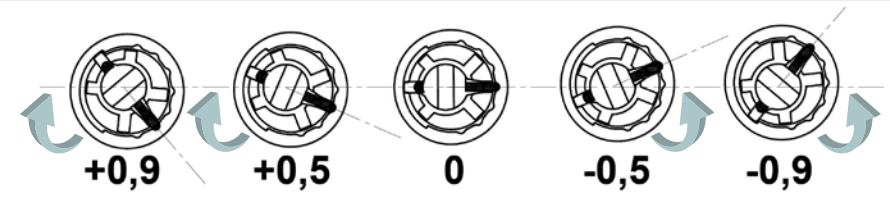

Use the door key head to increase or decrease the clamping force as shown left - two selectable points in each direction.

5. After adjustment, replace in the M12 set screw (6mm allen key) and tighten until a slight drag is noticed.

6. Tighten the M6x5 set screw (4mm allen key) and refit the plug.

RETURN TO STEP 7 ONCE HINGE ADJUSTMENT IS COMPLETE



DOOR CLEANING

⚠ At handover the door owner must be informed of the ongoing requirement for care and maintenance of the door.

A garage door should be cleaned every two months...

Garage doors are exposed to the elements all year round. Regular cleaning of the door and frame helps prevent excessive soiling that disrupts operation and degrades appearance. Failure to maintain or clean a door accelerates the ageing of a door. On average, a garage door should be cleaned every two months to keep it strong, intact and, of course, well-maintained. Under no circumstances should you wait until the door has stubborn dirt on it, which, under certain circumstances, can no longer be removed.

What not to use...

No caustic, abrasive or corrosive chemicals and substances, flood water, water runoff, or runoff from lead, copper or galvanic metal flashing should be allowed to come into contact with the door. A jet wash must not be used to clean any part of the door. Ash, cement, dust, animal waste, or foreign substances should be removed immediately. Do not apply excessive pressure when cleaning, doing so will affect the surface finish, leading a permanent change in its lustre. Failure to ensure the door is cleaned and maintained as described will invalidate the doors' warranty. Contaminants that come into contact with the door can contain grains that will oxidise and rust on the surface of the door causing discolouration spots. These rust spot discolourations are not an issue with door door's finish, but the result of contaminants and not covered under warranty. Issues of this kind can be reduced by regular cleaning.

What you need...

You need the following tools for cleaning: A clean cloth, clean warm water and some a car shampoo or similar. Caution: If sand has settled on the surface, you should work extra carefully to avoid scratching the paintwork of the garage door. In this case, it is best to work carefully with a garden hose and spray the door with lukewarm water to remove the coarsest dirt. Follow this by thorough cleaning with a cloth. If your garage door has a locking cylinder, it should only be cleaned with care products specifically for cleaning locking cylinders – do not use oil-based agents.

How to clean...

Work with a damp cloth and car shampoo to loosen dirt from garage doors. Aggressive scouring agents or solvents are not to be used, as they can attack the surface and even make it porous. Many garage doors have polymer glazing that gets dirty quickly. It is enough to simply wipe them off. However, if they have already become discoloured, the material can no longer be saved and should be replaced if necessary. To avoid damaging window surfaces, glass cleaner must not be used (due to aggressive ingredients). Never use abrasive cleaners, scrapers or razor blades, etc. Flush with flowing water. Clean with warm water, a small amount of mild plastic cleanser and clean, soft, lint-free rags.

Stainless steel...

Stainless steel garage door elements are also best cleaned with a clean, lint-free cloth and a mixture of water and car shampoo. However, if the door is heavily soiled, such as stains or limescale deposits, a stainless-steel cleaner - such as that used in the kitchen - should be used. You will achieve the best result if you use distilled water again after cleaning to rinse and then dry the surface. In this way, traces of limescale, which are often caused by hard tap water, are avoided.



Salt content...

Depending on where you live and the salt content of the air, you may need to clean a garage door more often – for full details, see the honesty booklet.



Scan the qr code to download a copy of the Teckentrup Honesty Booklet.

WHAT CAN I EXPECT FROM MY DOOR?



CarTeck side hinged garage doors and personnel doors are designed to provide access to and from a garage space.

CarTeck side hinged garage doors and personnel doors are not front doors!

Front doors must be compliant to the British Standard for pedestrian doorsets BSEN14351-1. Garage doors must be compliant to the British standard for garage doors BSEN13241-1

As a garage doors' primary function is to allow vehicular access and personnel access to a garage, they are designed to conform to different requirements when compared to a front door, which provides access to a living space.

It is important to note that the stated performance of our doors (made in the Declaration of Performance for CarTeck side hinged garage doors and personnel doors as part of the requirement of the British Standard for Garage doors) is lower than that required for a front door, but you can't get a vehicle through a front door! Most garages do not require the performance of a front door as they are unheated spaces designed to store a vehicle.

Below are the key points that you must accept regarding the performance of our doors. It's important that you take them on-board, as we want to be as transparent and honest about what you can reasonably expect from the products we sell.

LIGHT, DRAFTS & WATER INGRESS

When the door is closed, light ingress is to be expected. The door seals are reasonably effective at stopping light passage but will not eliminate it. This will be more pronounced generally where seals meet and particularly in corners. Where light can get in, so can a draft. With a well installed door that has seals in good condition, drafts will be minimal but the door is not sealed completely.

Under normal weather conditions water ingress should also be minimal, but you may experience some ingress, as with light and drafts, where seals meet and in corners. Under extreme conditions; driving rain and high winds, ingress can be expected to increase. Never jet wash a door, not only may it damage the finish but it can force open seals causing water ingress.

The threshold is a point where water ingress may occur. Gaps between the bottom seal and the threshold arising from a poorly fitted or uneven threshold will allow water ingress. If rain runoff is able to collect and pool at the bottom of a door instead of draining away from the door into a drainage channel, water ingress may occur. Fitting the door onto a stepped rebate behind a drainage channel is often effective in greatly reducing the likelihood of water ingress.

THERMAL PERFORMANCE

CarTeck side hinged garage doors have been tested for thermal performance and have a U value, as a complete door (3188mm wide x 2359mm in size), of 2.20 W/m²K (2.60 W/m²k for single leaf side hinged personnel doors). This is very good for a garage door!

When comparing U values, make sure you are comparing like-for-like. A complete door is different to the panel that a door is made from. The panels our doors are made from have a U value of just 0.56 W/m²K, but this does not reflect the real-world performance, so, make sure, when you compare performance, it's for a full door not just a panel!

Teckentrup UK Limited, Units 2-4 Opus 9 Industrial Estate,
Woburn Road, Winwick Quay, Warrington WA2 8UE

t: 01925 924 050

f: 08701 314 843

e: sales@teckentrup.co.uk

TECKENTRUP
DOOR SOLUTIONS



WWW.TECKENTRUP.CO.UK